

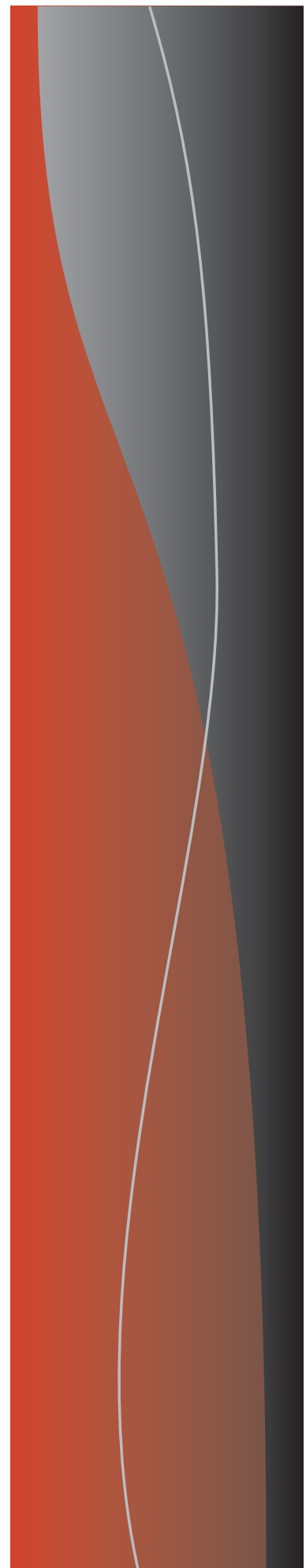

MX SERIES 250
MX SERIES 300
WASTE OIL HEATER

**Installation and Operating
Instructions**

Lanair Products LLC
4109 Capital Circle
Janesville, Wisconsin 53546
1-888-370-6531
www.lanair.com





BEFORE YOU BEGIN INSTALLATION...

IMPORTANT

Read and understand this manual completely before beginning installation.

- This heater is for commercial and industrial use only. **This unit is not intended for residential use.**
- This heater must be installed and/or inspected by a licensed heating contractor before operation. Installer should be trained and thoroughly familiar with the installation and operation of oil-fired heaters.
- Installation of this unit must be made in accordance with state and local codes or authorities having jurisdiction over environmental control, fuel, fire and electrical safety.
- N.F.P.A. (National Fire Protection Association Publications for Heater Installation)
 - NFPA No. 30 Flammable and Combustible Liquids Code
 - NFPA No. 31 Standard for the Installation of Oil Burning Equipment
 - NFPA No. 70 National Electric Code
 - NFPA No. 80 A&B Repair Garages and Parking Structures
 - NFPA No. 211 Standard for Chimneys, Fireplaces, Vents, and Solid Fuel Burning Appliances

The above standards are available from the National Fire Protection Assn., Battery March Park, Quincey, MA 02269

- Read and familiarize yourself with these instructions and associated photos, diagrams and illustrations before beginning installation or operation. These instructions should be followed closely, to achieve the best possible results.

If you have questions or concerns at any time during the installation, stop the installation and contact a Lanair Service Representative.

- Check to make sure you have all the required components needed for proper installation and operation.
- Check each component for visible damage. If you find a damaged component, contact a Lanair Service Representative for a replacement. Do not install broken or damaged parts.
- This heater is designed to provide economically and environmentally friendly disposal of waste oil. Due to the nature of the fuel used, this heater should not be relied upon as the sole source of heat.
- Read and understand the warranty. Fill out the enclosed warranty card and return within 10 days of purchase.

QUESTIONS?... Contact Customer Service at 1-888-370-6531 M-F 8:00 am- 4:15 pm CST

MX SERIES 250 WASTE OIL HEATER

MX SERIES 300 WASTE OIL HEATER

Installation and Operating Instructions

Table of Contents:

	Rules For Safe Installation and Operation	page 2
Sec. 1	General Specifications and Hazards	page 4
Sec. 2	Heater Installation	page 10
Sec. 3	Chimney /Vent System	page 12
Sec. 4	Draft	page 15
Sec. 5	Fuel Supply Tank /Piping Installation	page 15
Sec. 6	Fuel Supply Pump/Piping	page 17
Sec. 7	Compressed Air Installation	page 19
Sec. 8	Electrical Connections/Wiring Diagram	page 20
Sec. 9	Controls	page 23
Sec. 10	Priming Fuel Pump	page 25
Sec. 11	Burner Start-Up Procedure	page 27
Sec. 12	Flame Adjustment	page 29
Sec. 13	Maintenance Schedule / Service Adjustments	page 32
Sec. 14	Troubleshooting	page 44
Sec. 15	Warranty Certificate	page 49
Sec. 16	Burner Reference Diagram	page 51



Section 1 - General Specifications & Hazards

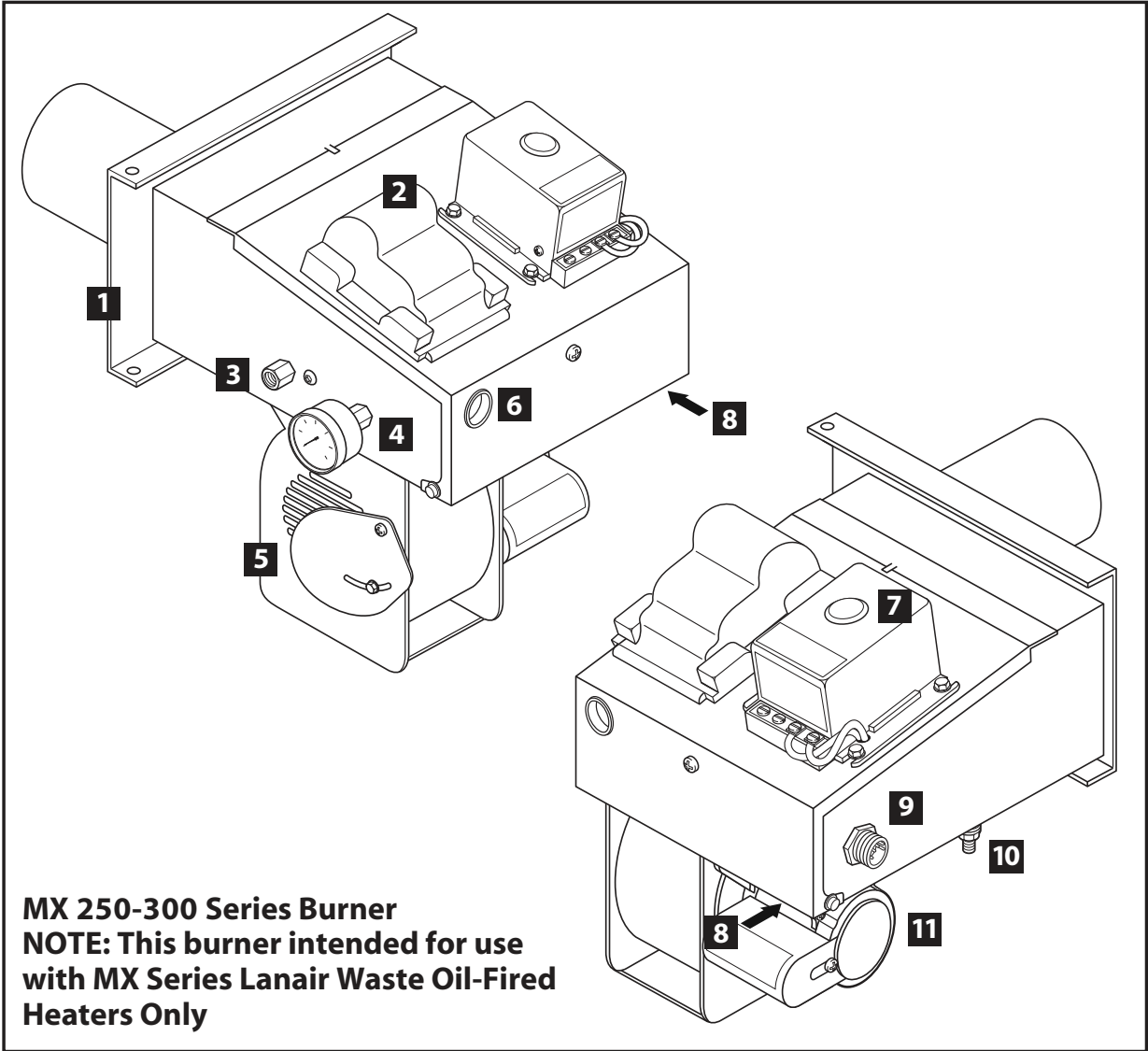

MX 250-300 Series Burner
NOTE: This burner intended for use with MX Series Lanair Waste Oil-Fired Heaters Only

No.	Description
1	Mounting Plate
2	Ignitor Transformer
3	Fuel Line Inlet
4	Fuel Pressure Gauge
5	Combustion Air Baffle
6	View Port
7	Oil Primary Safety Control
8	Waste Oil/Fuel Oil Switch
9	Quick Disconnect Receptacle
10	Air Supply Inlet
11	Combustion Blower Motor

**Burner Assembly-
Performance Ratings**

- Voltage 115 vac
- Cycles 60 hz
- Total Operating Amperage 5.8
- Weight31 lbs
- Oil Primary 0.2 amps
- Pre-Heater Block2.6 amps
- Ignitor Transformer 0.3 amps

QUESTIONS?... Contact Customer Service at 1-888-370-6531 M-F 8:00 am- 4:15 pm CST

Section 1 - General Specifications & Hazards

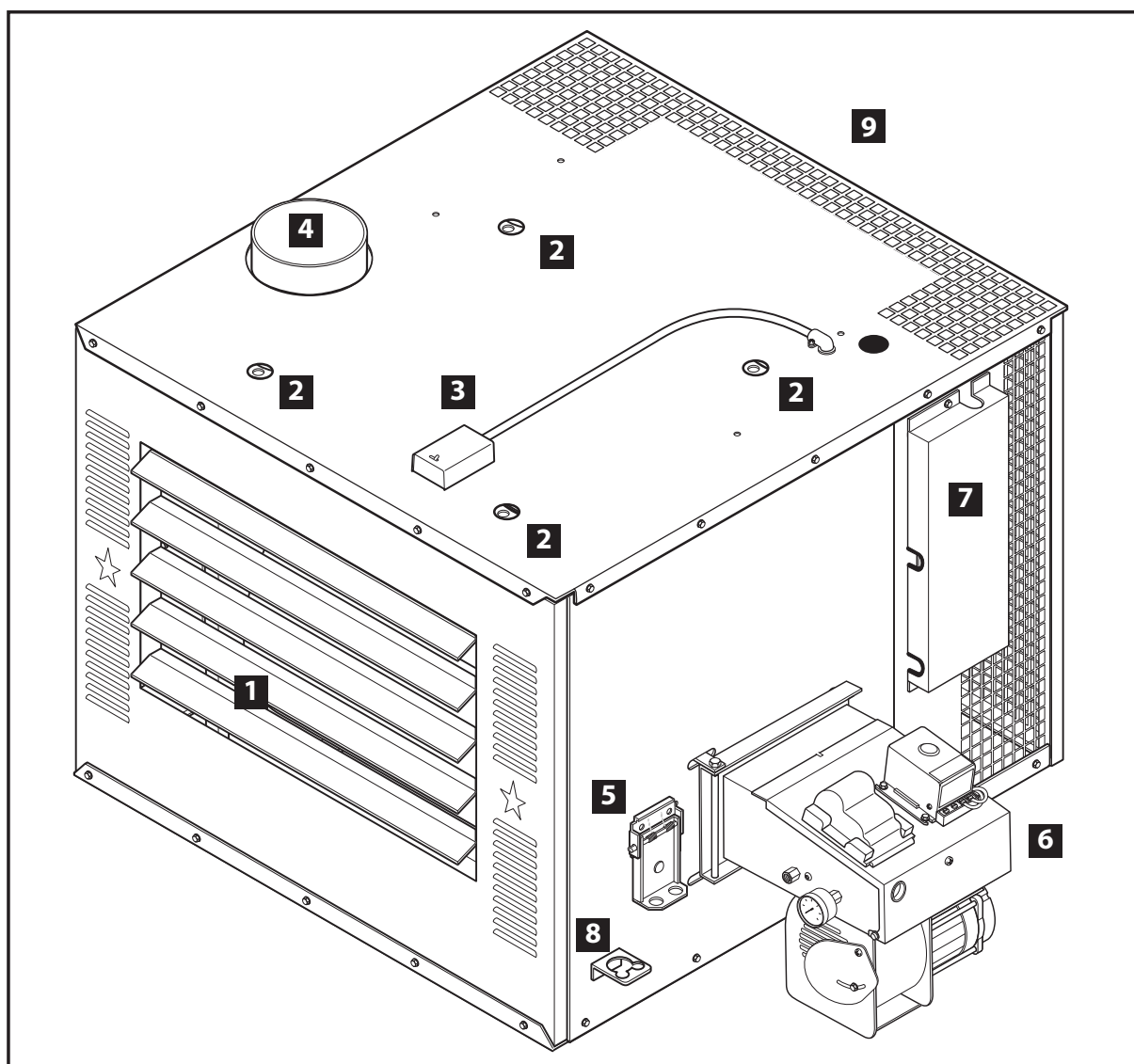

No.	Description
1	Adjustable Air Flow Louvers
2	Mounting Holes
3	Fan Limit Switch
4	8" Exhaust Flue
5	Flame View Port
6	Burner Assembly
7	Electrical Connections Cover
8	Secondary Air Filter/Regulator Location
9	Fan Assembly (Internal)

Visit our website at: www.lanair.com



Section 1 - General Specifications & Hazards

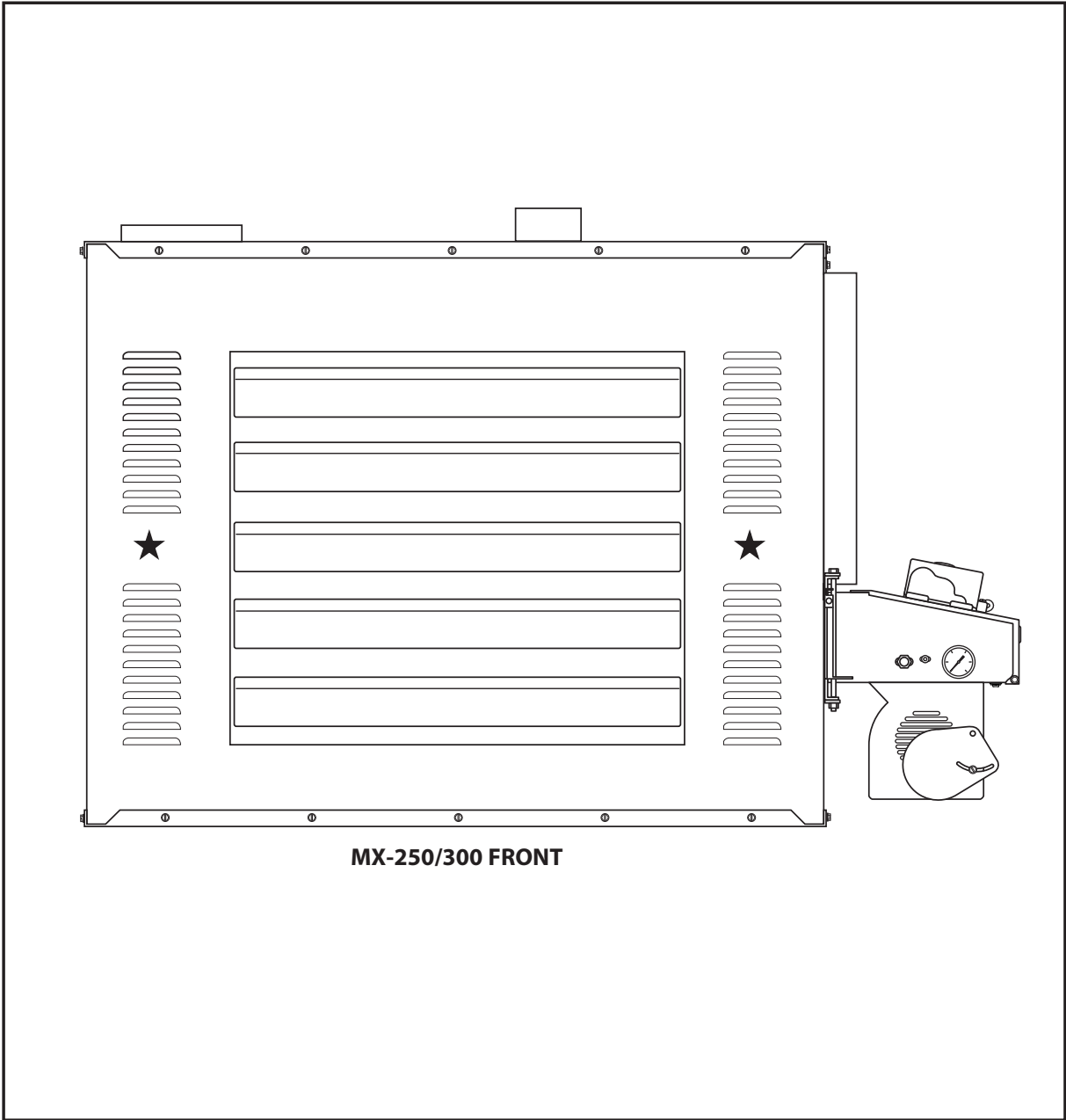

MX-250/300 FRONT

DIMENSIONS:

MX-250	Height: 36"	Width: 46"	Depth: 48"	Weight: 630 LBS
MX-300	Height: 36"	Width: 46"	Depth: 48"	Weight: 630 LBS

FIRING CAPACITIES:

MX-250	Nozzle @	1.79	gallons/hour, No. 2 fuel oil/used crankcase oil
MX-300	Nozzle @	2.14	gallons/hour, No. 2 fuel oil/used crankcase oil

QUESTIONS?... Contact Customer Service at 1-888-370-6531 M-F 8:00 am- 4:15 pm CST

Section 1 - General Specifications & Hazards

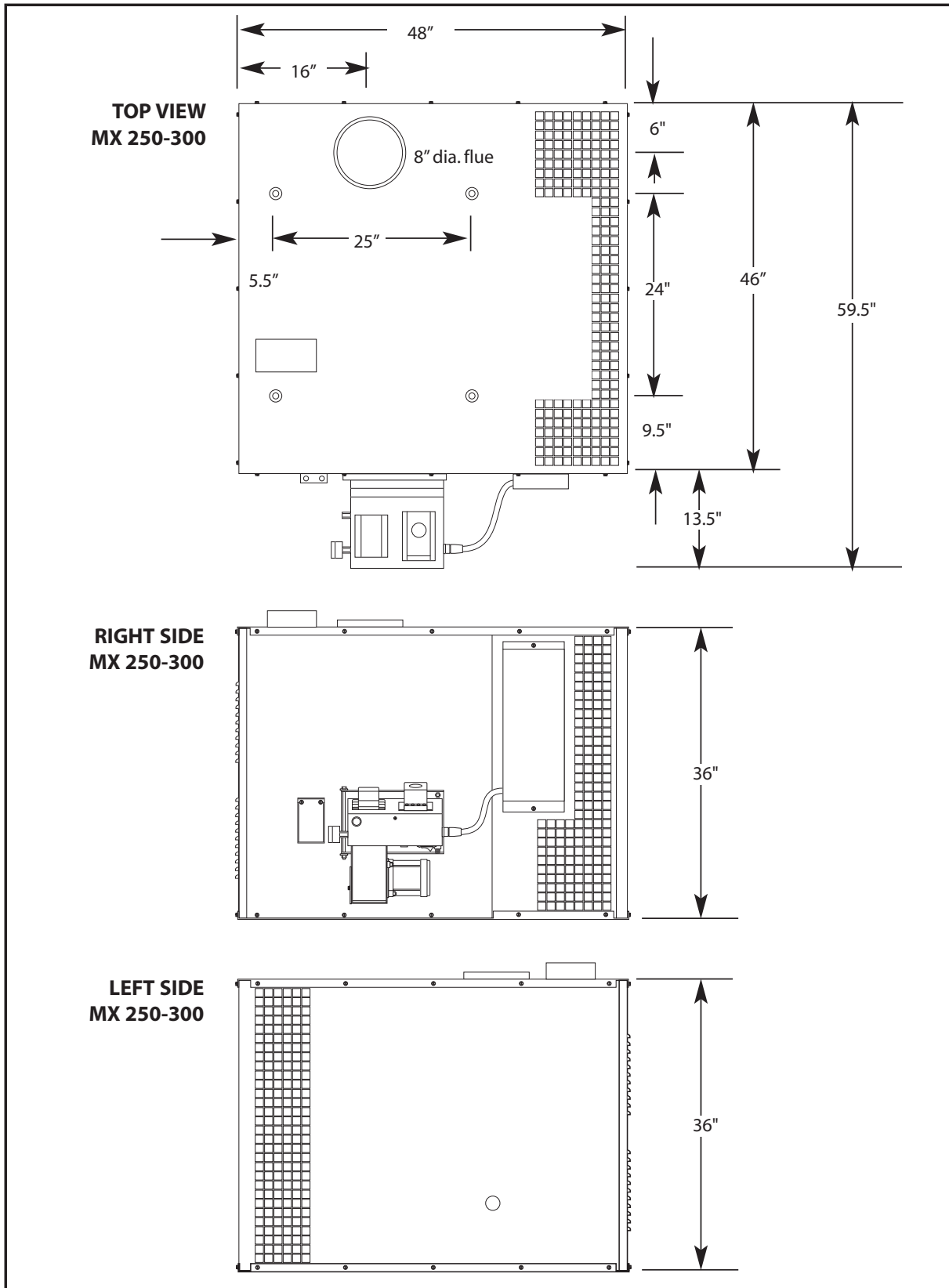

Visit our website at: www.lanair.com



Section 1 - General Specifications & Hazards

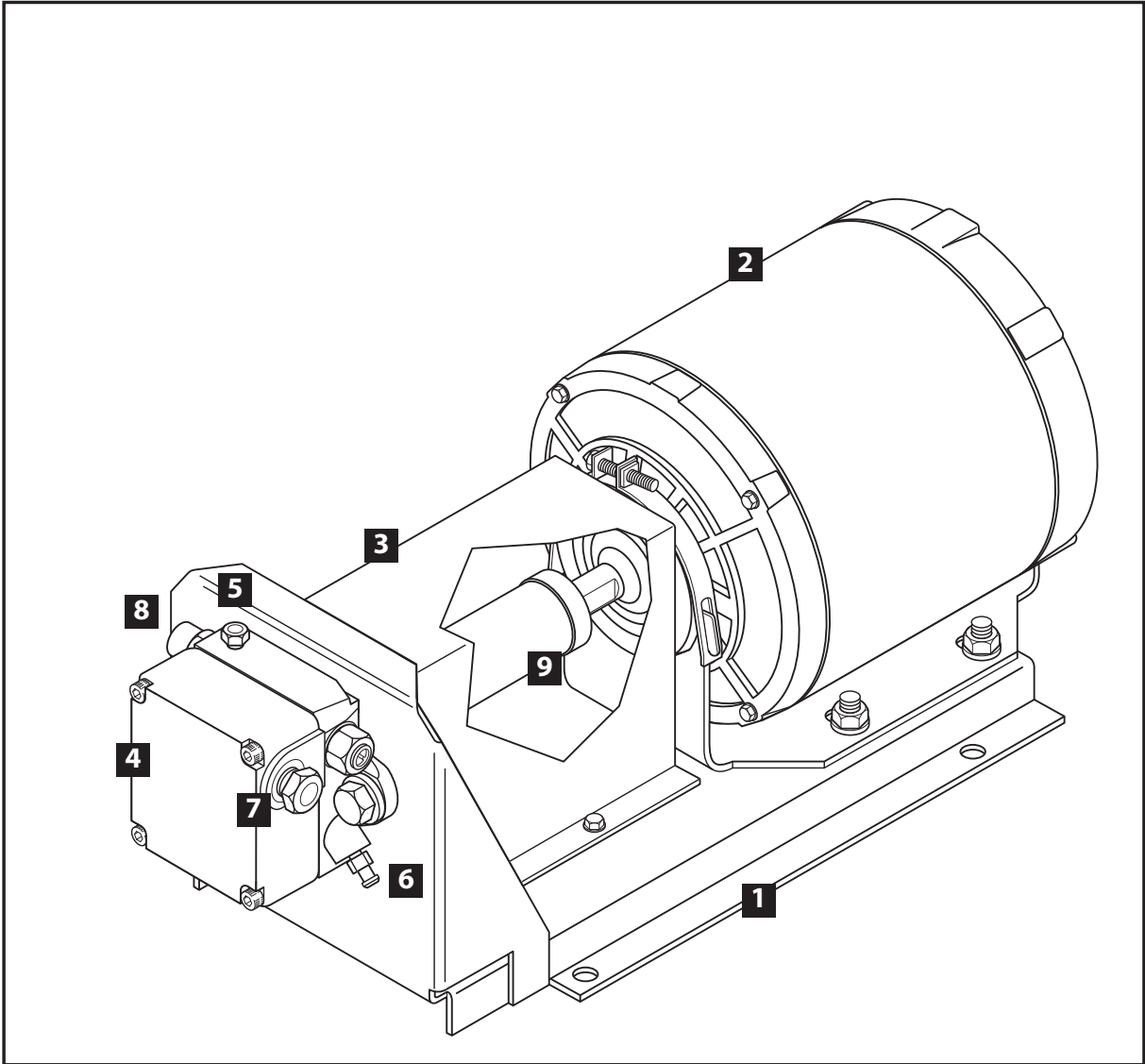

No.	Description
1	Pump Platform
2	Pump Motor
3	Pump Guard
4	Pump
5	Pressure Gauge port
6	Easy Flow Bleed Valve
7	1/4" NPT Inlet
8	1/8" NPT Outlet
9	Pump coupler

**Pump Assembly-
Performance Ratings**

Voltage 115 vac
 Cycles 60 hz
 Weight 24 lbs
 Pump Motor 5 amps

QUESTIONS?... Contact Customer Service at 1-888-370-6531 M-F 8:00 am- 4:15 pm CST

Section 1 - General Specifications & Hazards

DIMENSIONS:

MX-250	Height: 36"	Width: 46"	Depth: 48"	Weight: 630 LBS
MX-300	Height: 36"	Width: 46"	Depth: 48"	Weight: 630 LBS

FIRING CAPACITIES:

MX-250	Nozzle @ 1.79 gallons/hour, No. 2 fuel oil/used crankcase oil
MX-300	Nozzle @ 2.14 gallons/hour, No. 2 fuel oil/used crankcase oil

MINIMUM CLEARANCE TO COMBUSTIBLES:

Top	6"	Chimney Connector	18"
Sides	18"	Rear	6"
Burner Side	38"		
Front	60"	Bottom	24"

THIS HEATER IS DESIGNED TO BURN THE FOLLOWING APPROVED FUELS:

Used 5W through 50W Crankcase Oils
No. 1 and No. 2 Fuel Oils

- The Lanair Heater provides the owner with a dependable, versatile and simple means of burning No.1 and No.2 fuel oils and 5W through 50W used crankcase oils. Maintained correctly, the heater will give you years of service. Please carefully read this owner's manual. If in any case you have a problem with your heater, or its installation, you should contact the Lanair Customer Service Department at 1-888-370-6531.
- **This heater is not designed for attachment or use with ductwork.**
- **Do not attempt to start the burner when excess oil, oil vapor, or fumes have accumulated! Never press the red button on the oil primary control more than twice! This could cause excess vapor, or fuel to ignite causing damage to the heater and/or chimney.**
- Do not store or use gasoline, or any other flammable liquid and/or vapors near this heater.
- This heater is not designed for use in hazardous atmospheres such as: Paint Shops, Feed Mills, installations where explosive or flammable conditions are present or could occur.

! **WARNING!** Lanair heaters rely on natural draft. Down drafts (positive pressures) in the heaters chimney will occur in buildings where negative pressures are created by exhaust fans, (car exhaust, paint booths, etc). Do not try to use a power vent to overcome a down draft (positive pressure). An adequate make-up air system is required when exhaust fans are used (consult your heating contractor).

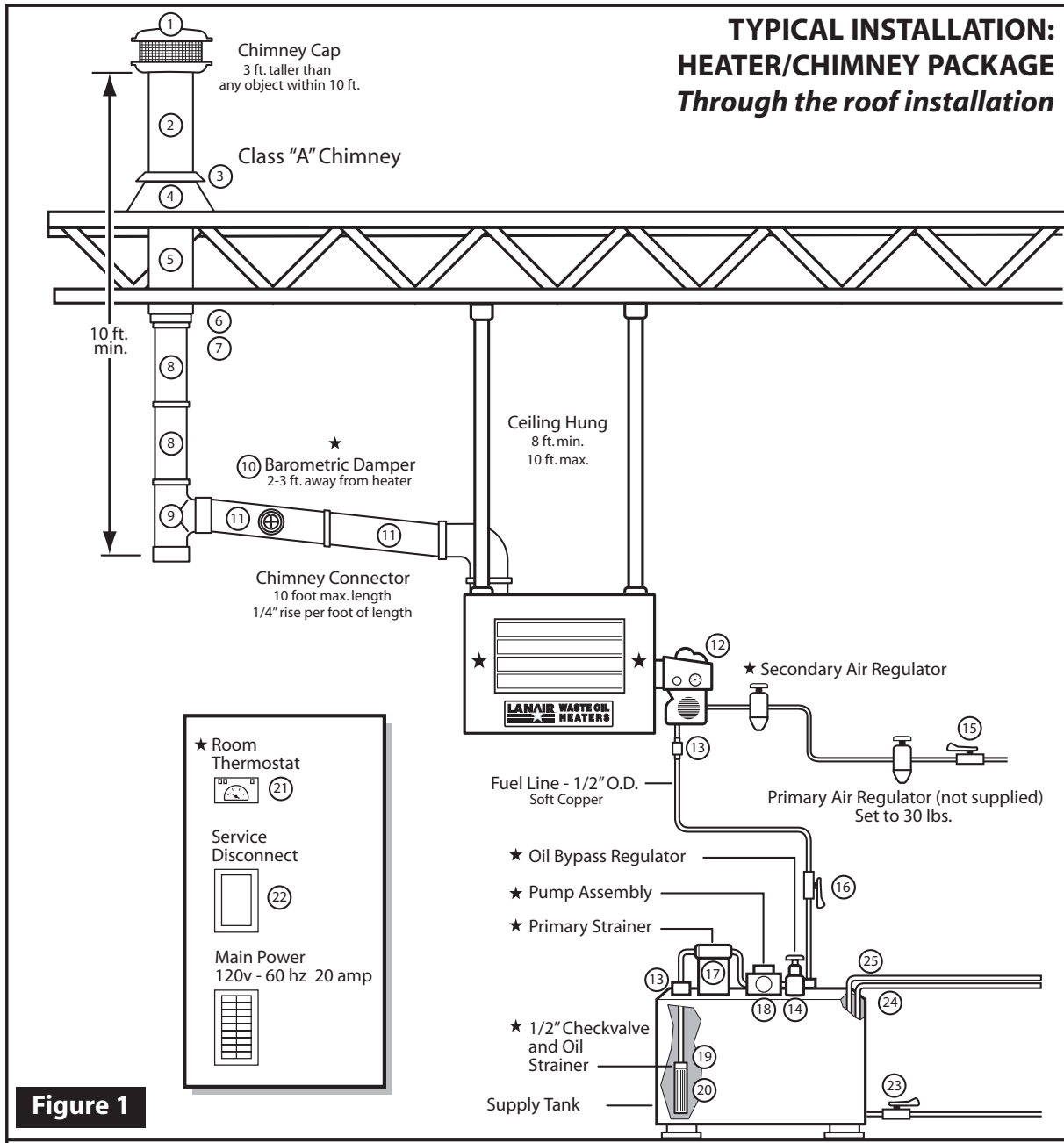

Figure 1

- | | | |
|--------------------------------|-------------------------------------|----------------------------------|
| 1. Chimney Cap | 10. Barometric Damper | 19. Check Valve |
| 2. Chimney Pipe (36") | 11. Black Pipe (24") | 20. Pick-up Tube Strainer |
| 3. Storm Collar | 12. Burner | 21. Thermostat |
| 4. Roof Flashing | 13. Union | 22. Service Disconnect |
| 5. Chimney Pipe (36") | 14. Oil Bypass Pressure Reg. | 23. Tank Drain |
| 6. Finishing Collar | 15. Shut-off Valve | 24. Fill Pipe |
| 7. Slip Connector (14") | 16. Shut-off Valve | 25. Tank Vent |
| 8. Black Pipe (24") | 17. Suction Line Strainer | |
| 9. Black Tee w/cap | 18. Fuel Pump | ★ Included with Heater |

QUESTIONS?... Contact Customer Service at 1-888-370-6531 M-F 8:00 am- 4:15 pm CST

Section 2 - Heater Installation

General Requirements

1. Do not install the heater on a combustible surface of any kind. For minimum clearance to combustible material (see Page 9)
2. Install the heater in a location to utilize total heat throw.
3. Install the heater in a location to permit a correct outdoor chimney exit to eliminate down drafts, and provide easy chimney installation and maintenance. Class A chimney **MUST** be used when passing through any wall or ceiling. See Section 3 Chimney Installation
4. Install the heater in a location to permit the fuel supply to be as close as possible.
5. Do not install the heater more than 10 feet above the top of the fuel supply tank.
6. Before suspending the heater check the supporting structure and reinforce if necessary to support the weight of the heater/system.
7. Use 3/8" steel threaded rod to suspend the heater from a capable load carrying ceiling structure when not using the Lanair Waste Oil Storage Tank.
8. The heater must be suspended level for proper operation. A heater that is not level could cause a hazardous situation in which personal injury or property damage may result.

Adjustable Locking Louvers

The MX Series heaters feature spring loaded locking louvers. To adjust:

- Slowly push the louver to the left until the locking pin disengages. **NOTE:** Do not allow the pivot pin to come out of the hole.
- Tilt the louver forward/backward until desired position is obtained.
- Release louver so locking seats into the hole.

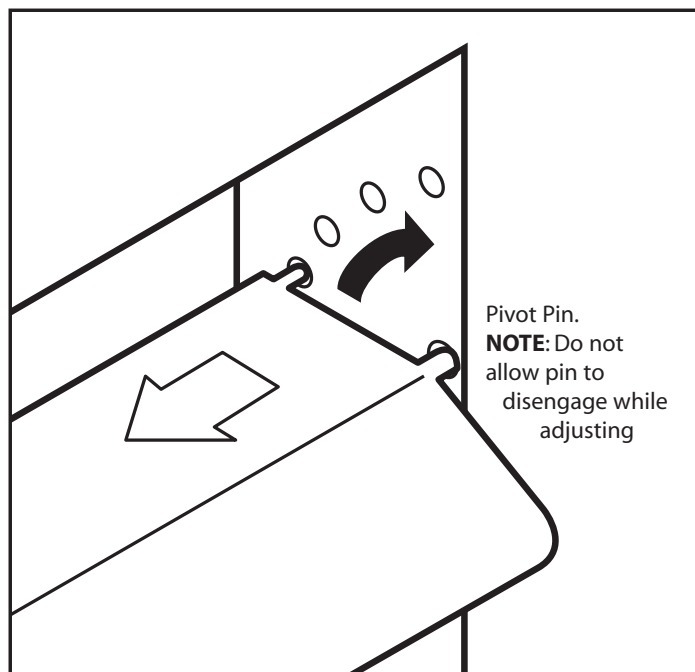

Visit our website at: www.lanair.com



Section 3 - Chimney/Vent System

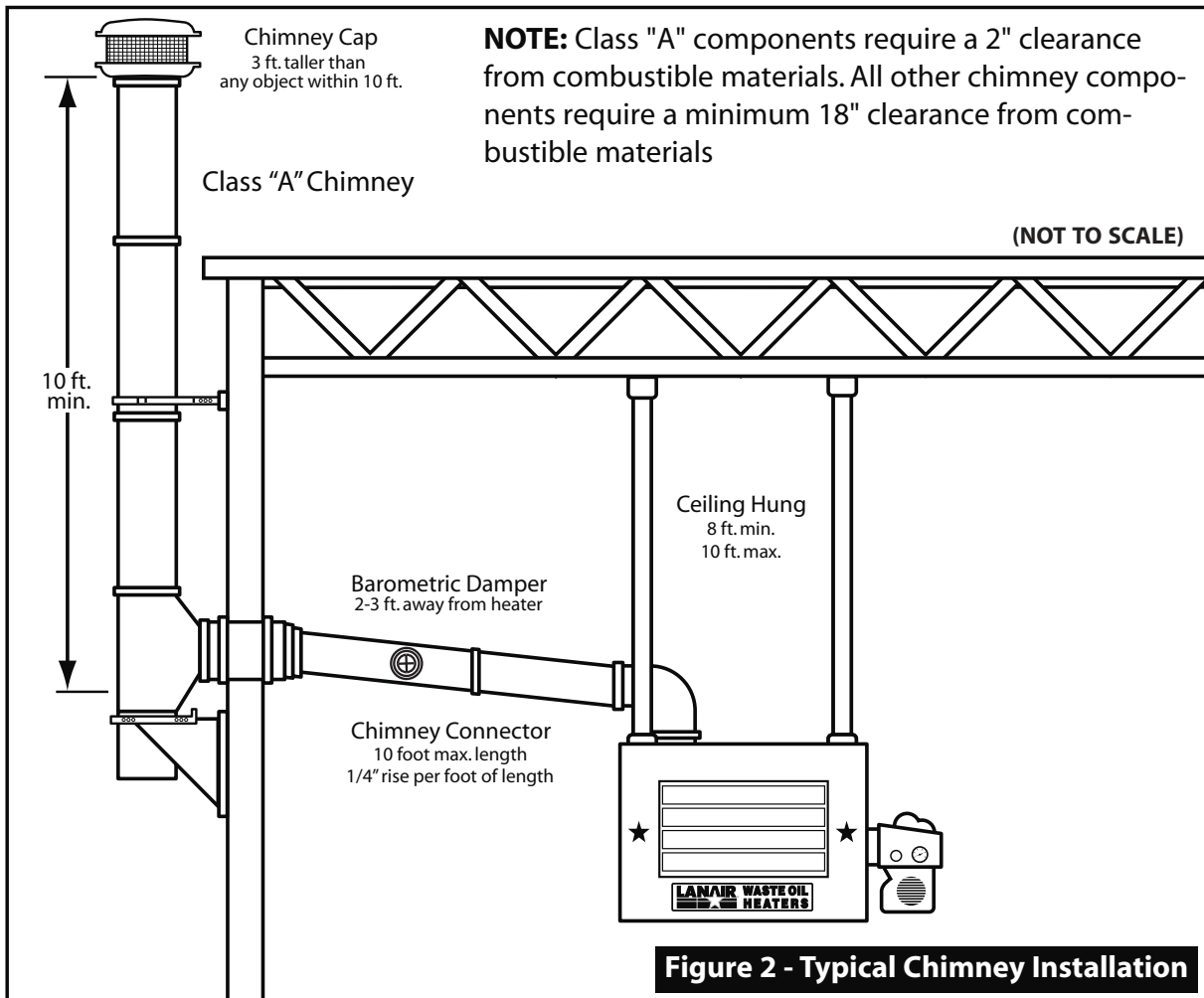

General Requirements

1. Safe operation of any gravity vented heating appliance requires a proper air make-up system to prevent the heater exhaust gases from being drawn into the building. These gases could cause death, serious injury, and/or property damage. Exhaust fans, paint booths may cause draft problems.
2. Never vent this heater into another heating appliances chimney. Never vent into "Class B" chimney. Gas heaters use "Class B" chimney, it is rated for a much lower temperature than is required for your waste oil furnace. This heater must have its own separate "Class A" chimney.
3. Inspect and maintain the chimney on an annual basis.



Failure to provide proper venting of the heater exhaust gases could result in death, serious injury, and/or property damage. FOLLOW CHIMNEY MANUFACTURERS INSTRUCTIONS.

QUESTIONS?... Contact Customer Service at 1-888-370-6531 M-F 8:00 am- 4:15 pm CST

Section 3 - Chimney/Vent System

General Requirements (cont.)

4. Install a U.L. listed barometric damper in the chimney. Do not reduce or enlarge the vent pipe.
5. **Do not use more than one 90° elbow. Each 90° elbow equals a 10' run of chimney. The maximum run for the chimney connector is 30'.**
6. To prevent the drawing of exhaust gases into the building, keep the barometric draft control at least 24" from the heater, exhaust fan etc..
7. Position the draft control as shown. Barometric Damper gate pins must be horizontal (Parallel to the floor) for proper operation.
8. Secure all connections in the chimney connector with 3 screws per joint.
9. The chimney connector clearance to any combustible material is 18". The "Class A" chimney clearance to any combustible is 2". Follow the chimney manufacturer's instructions.
10. Do not install heat re-claimers, manual draft controls, or any other type of restrictive control in the chimney.
11. Install clean out tee with a cap, at the transition of the chimney. **FOLLOW CHIMNEY MANUFACTURERS INSTRUCTIONS.**
12. Use "Class A" insulated chimney pipe to vent exhaust gases through wall, ceilings, attics, roofs, combustibles, etc. Class A chimney must be used for the entire run once passing through a wall of ceiling.
13. Vent chimney at least 3 feet above the roof and at least 3 feet higher than any portion of the building, roof, or obstruction within 10 feet of the chimney.
14. The chimney cap should be at least 3' above the chimney exit through the roof.
15. Do not use a rotating chimney cap. Use a non-restrictive "Class A" cap made for the type "Class A" chimney you are using. Follow chimney manufacturer's instruction.
16. The chimney must be capable of producing a negative -.02 W.C. draft when cold and -.06 W.C. draft when hot. Refer to Section 4 Draft Instructions. Refer to Section 3.10 for typical Chimney Installation.

NOTE: Do not install chimney in front of the heater (in air stream of fan)

Barometric Damper Position

HORIZONTAL



VERTICAL

NOTE: Barometric Damper may be mounted horizontally or vertically. Angle gate pins must be horizontal for proper operation



Section 3 - Chimney/Vent System

17. If you are unable to attain the proper draft, check for exhaust fans in the building. To test if there is a problem, open an overhead door and see if you now have the proper draft. You may have to add one or more sections of "Class A" chimney to the roof to get the proper draft.
18. The heater and chimney must be installed in accordance with all state and local codes. The heater must be installed in accordance with the specifications listed in this manual. The chimney must be installed per the chimney manufacturer's instruction. Use "Class A" chimney only.

Chimney Configurations Using Top Vent (not to scale)

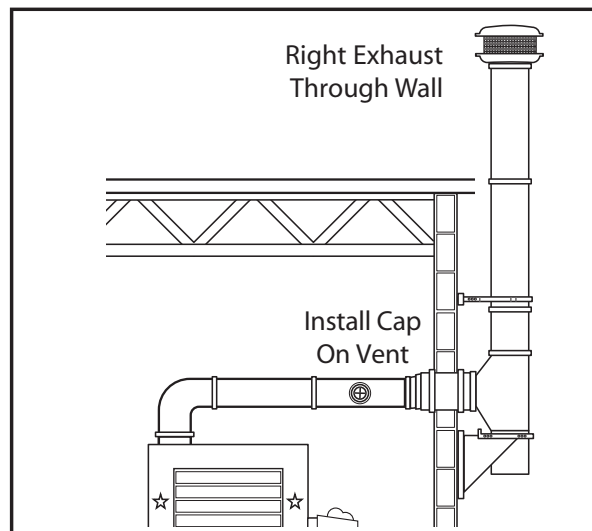
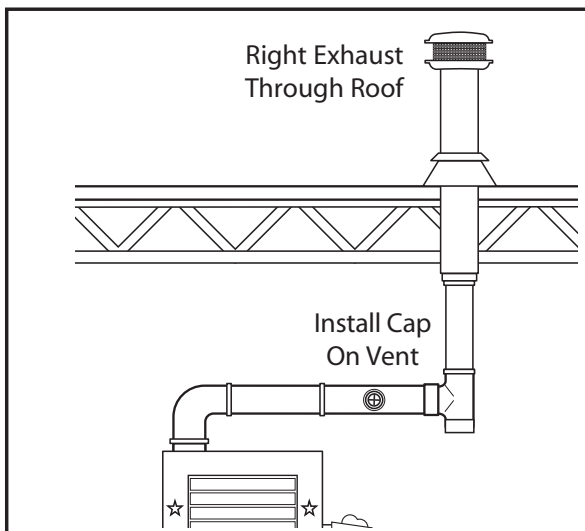
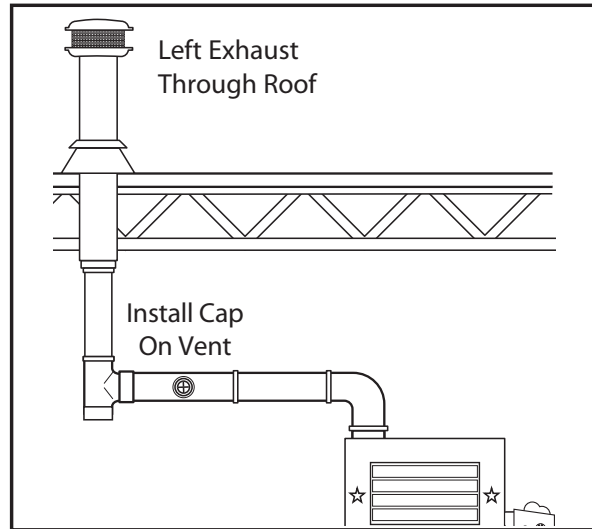
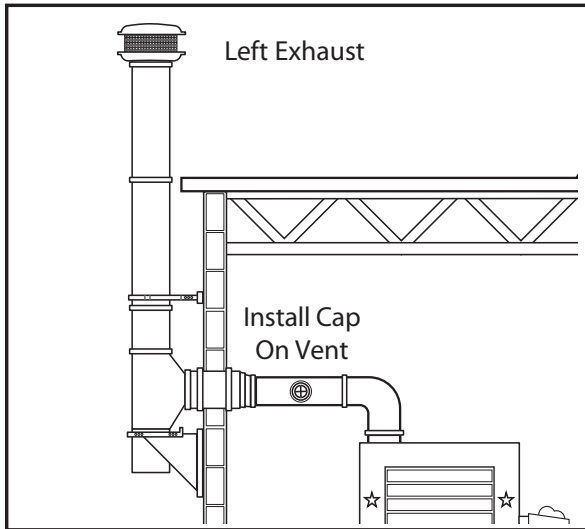

QUESTIONS?... Contact Customer Service at 1-888-370-6531 M-F 8:00 am- 4:15 pm CST

Section 4 - Draft

The Lanair heater should have a (negative) $-.02$ draft reading when cold, and a (negative) $-.06$ when hot. Check the heater when it is running after 45 minutes. If the reading is not what it should be, adjust the barometric damper according to the instructions provided with the damper. The draft reading should be taken with a manometer. Consult your heating contractor, or a manometer can be purchased from the Lanair Customer Service Department .

Section 5 - Fuel Supply Tank Installation

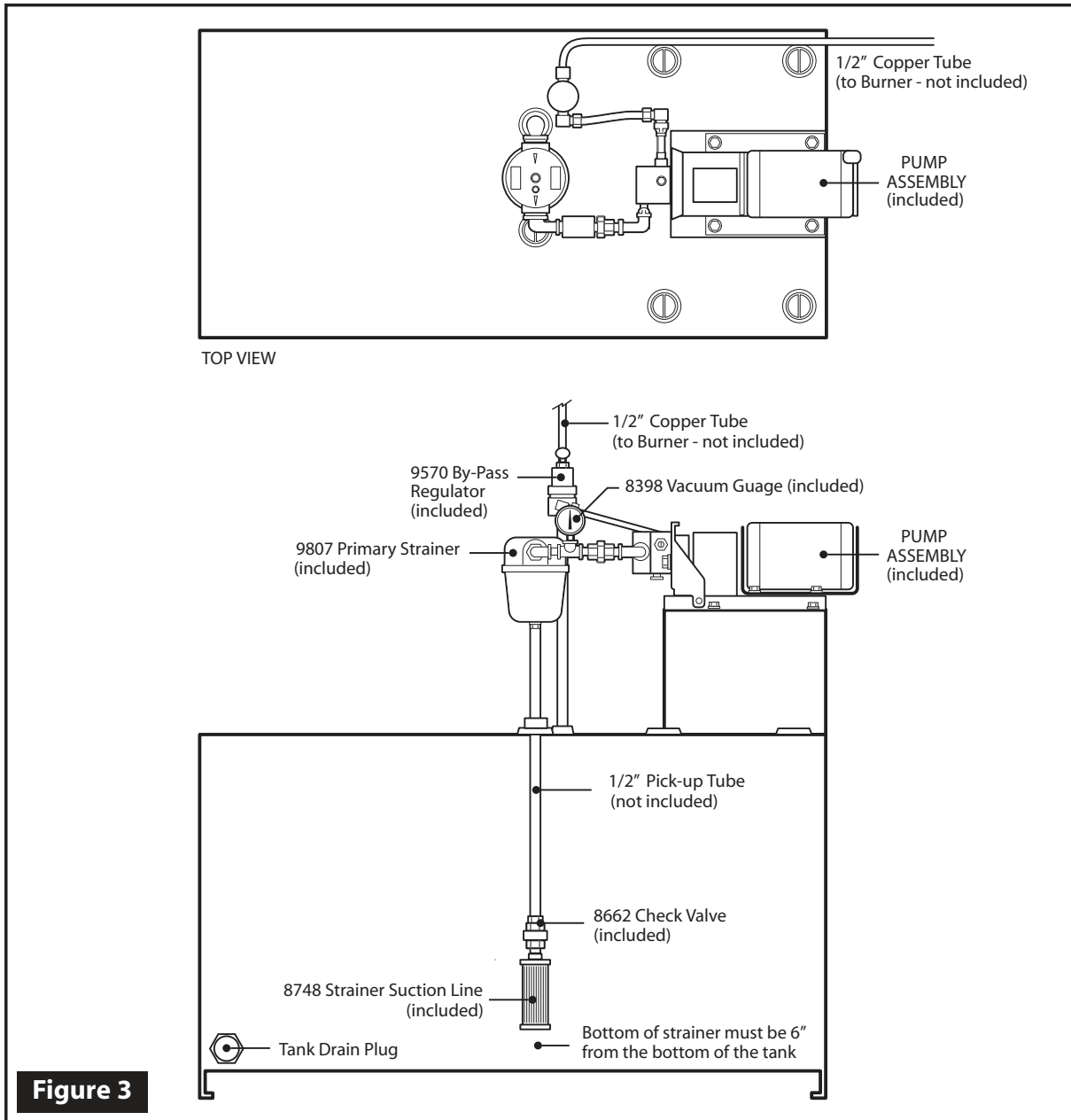

Figure 3



If using a Lanair supply tank follow instructions included with the tank.

Visit our website at: www.lanair.com



Section 5 - Fuel Supply Tank Installation



If using a Lanair supply tank follow instructions included with the tank.

General Requirements

1. The fuel supply tank and supply lines must be installed in accordance with the National Fire Protection Association requirements, as well as State and Local ordinances.
2. Regulations require oil storage tanks located inside not to exceed 275 gallons individually, and are not to exceed a total capacity of 550 gallons in one building. Check State and Local codes.
3. Locate the fuel supply tank inside the building as close to the heater as possible. It should be no further than 25 feet from the heater to avoid oil flow problems.
4. The fuel supply tank must be mounted below the burner and the by-pass regulator. Mounting the fuel supply tank above the burner will create head pressure and over-fire the burner voiding the warranty.
5. Pitch the fuel supply 2° with the drain valve at the lowest end to drain off water and sludge. Sludge may have to manually be removed.
6. **Some ordinances may require the fuel supply tank to be vented to outside and above the roofline. Check State and Local codes. Keep the vent clear.**
7. Install the fuel tank fill pipe at the end of the tank and above the drain.
8. Label the fuel tank for the recommended fuels.
9. Strain all fuel with a 50 X 50 mesh strainer before putting fuel into the tank.
10. When filling the fuel tank with a motorized pump, never leave unattended to prevent over filling and/or spillage.
11. Keep cap on the fuel tank when not filling.



For optimum performance, the waste oil pump manufacturer recommends that multi-weight oils such as 5W-30W be maintained at 32° F minimum and straight weight oils such as 40W and 50W be maintained at 50° F minimum.

QUESTIONS?... Contact Customer Service at 1-888-370-6531 M-F 8:00 am- 4:15 pm CST

Section 6 - Fuel Supply Pump/Piping

General Requirements

1. Mount the fuel supply pump in a horizontal position (shaft horizontal) near the fuel supply tank.
2. The oil pump has a maximum suction lift of 14 feet. Suction lift is the length of pipe run from the bottom of the pick up strainer to the fuel supply pump.
3. The fuel pump/motor are intended for indoor use only.
4. The fuel pump contains an internal strainer that periodically needs to be cleaned. This internal strainer is mounted behind the pump cover. Before removing the pump cover make sure you have a new gasket on hand. Contact the Lanair Customer Service Department for the proper gasket for your model of pump, at 1-888-370-6531.
5. Install the suction supply line from the inlet side of the fuel pump into the fuel tank opposite the drain.
6. Install a 1/2" inside diameter (.493) steel pipe, or 1/2" outside diameter copper throughout the suction supply line and pick up tube. The use of smaller line, or rubber, plastic or hydraulic line is unsafe and will void your warranty.
7. Use thread sealing compound on all pipe thread connections. **Do Not Use Teflon Tape.**
8. Install the suction line strainer in the suction line. Make sure the suction line strainer is 6" off the bottom of the tank. The suction line strainer may be mounted horizontally or vertically. Consider accessibility.
9. Install a 1/2" NPT pipe union between the suction line strainer and the pick up tube to allow for service on the pick up tube.
10. Install the check valve (arrow facing towards the pump) on the bottom of the pick up tube.
11. Install a vacuum gauge in the suction line. This gauge will indicate when service is needed on the strainer, pump or connections.
12. Install a 1/2" inside diameter (.493) steel pipe, or 1/2" outside diameter copper from the fuel by-pass regulator (port marked "T") to the fuel supply tank. Do not allow this line to protrude into the tank more than 1". **The use of smaller line, or rubber, plastic or hydraulic line is unsafe and will void your warranty.**
13. **Do not allow the fuel level in the tank to cover the return line.**



Section 6 - Fuel Supply Pump/Piping

14. Install the fuel supply line from the fuel by-pass regulator (port B) to the inlet port on the left side of the burner using 1/2" inside diameter (.493) steel pipe, or 1/2" outside diameter copper tubing. The maximum distance of this line is 25 feet. The fuel supply line must be run below the burner at all times. If the fuel supply line runs above the burner it will create head pressure. This head pressure will over-fire the burner voiding the warranty.
15. Install a union in the supply line close to the burner for service.
16. Install a shut-off valve in the fuel supply line at the fuel by-pass regulator for service.
17. Use 37° flare fittings on all copper tubing connections. Do not use compression fittings.
18. Keep the fuel supply lines 1" off any outside walls.
19. **The fuel supply line must gradually rise to the burner. It should not be higher than the burner.**
20. **Clean all lines, fittings, and parts internally before assembly.** A small burr or piece of rust could plug the nozzle. See Section 2 for an illustration of a typical pump and piping installation.

- B.** Port to the oil inlet on the burner assembly. Install 1/2" O.D. min. copper tubing, or 1/2" schedule 40 pipe. Failure to install this line properly will result in damage to your heater, and will void your warranty.
- T.** Port to the oil supply tank for the overflow return line. Install 1/2" O.D. min. copper tubing, or 1/2" schedule 40 pipe. **This line MUST run straight into the tank, and should not be sub-merged in oil. No elbows should be used. Failure to install this line properly will result in damage to your heater, and will void your warranty.**
- P.** Port from the outlet side of your fuel supply pump. Install 1/2" O.D. min. copper tubing, or 1/2 schedule 40 pipe. **Failure to install this line properly will result in damage to your heater, and will void your warranty.**

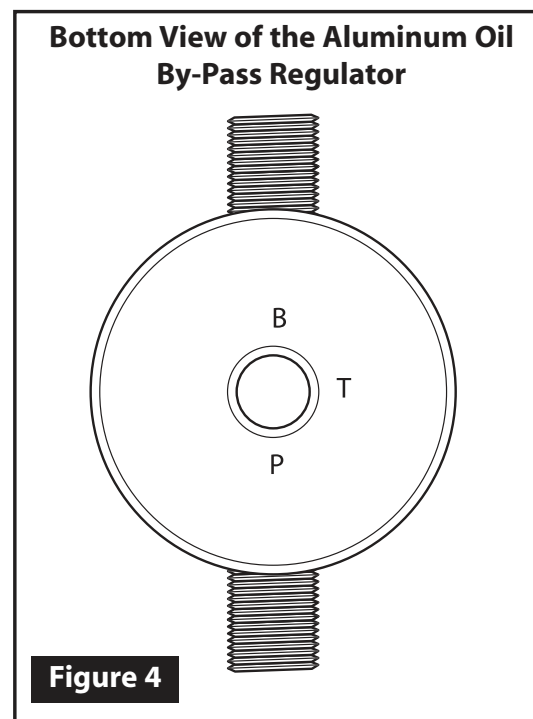

Section 7 - Air Supply Installation

General Requirements

1. Install an air pressure supply line connection to the air filter/regulator on the rear of the heater.
2. The air supply source must be capable of producing 2.0 CFM @ 60 PSI.
3. Install a shut off valve in the air supply line for service.
4. Install a primary air filter/regulator with a gauge (capable of reading line pressure) in the air supply line prior to the air filter/regulator mounted on the furnace. The primary air filter/regulator **is not supplied** with the furnace.
5. If the primary air regulator does not have a filter with a bowl, a condensate drain leg must be installed in the air supply line.
6. Install a quick disconnect at the air filter/regulator on the furnace for service.
7. For the ease of installation install a flexible air line (.250 I.D. minimum) from the quick disconnect to the primary air regulator.
8. The air supply line must be pitched uphill from the primary regulator to the furnace to prevent condensation from entering your burner.
9. Open all air shut off valves, and set the primary air regulator at 30 PSI.
10. Set the air filter/regulator on the front of the furnace to 18 LBS. See illustration below (Fig. 5) for a typical air pressure supply installation.

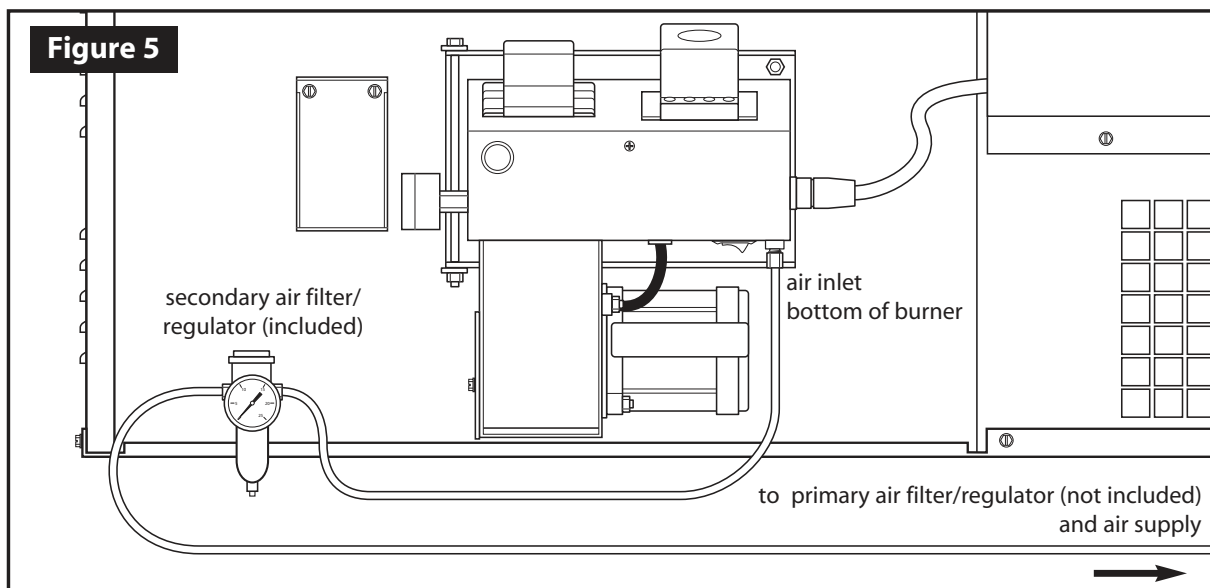

Visit our website at: www.lanair.com



CAUTION: HAZARD OF ELECTRICAL SHOCK!

Main Electrical Installation

1. All wiring must comply with the National Electrical Code. State and Local Ordinances, and be wired by a qualified electrician.
2. **Electrical service MUST be connected to a separate 20 AMP, 115 VAC, 60 HZ single phase circuit.**
3. Electrical service connections are made in the electrical junction box on the side of the heater.
4. The heater must have a safety equipment ground from the main electrical service, stranded 12 GA minimum.
5. The electrical conductors for electrical service to the heater MUST be stranded 12 GA minimum.
6. Install a manual service disconnect near the heater, and label its function.
7. The supply voltage must be maintained at a minimum 110 VAC.
8. The electrical conductors from the main electrical service must be within approved conduit.
9. Keep all electrical conductors and conduit away from the chimney connector as well as any other hot surfaces. Refer to Figure 7, Wiring Diagram for color code, etc. Keep the power off until the heater is ready to be started. Refer to Section 12 Start Up Procedure.

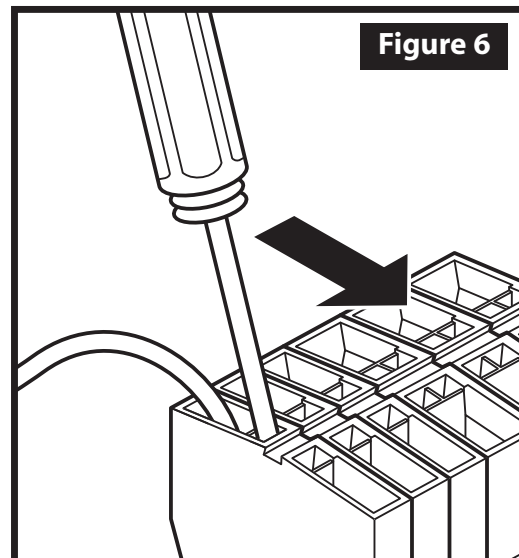

Remove wires from the block by inserting a small flat tip screwdriver into the top slot. Push tip all the way down and push forward. Remove wire.

Section 8 - Electrical Connections

Figure 7

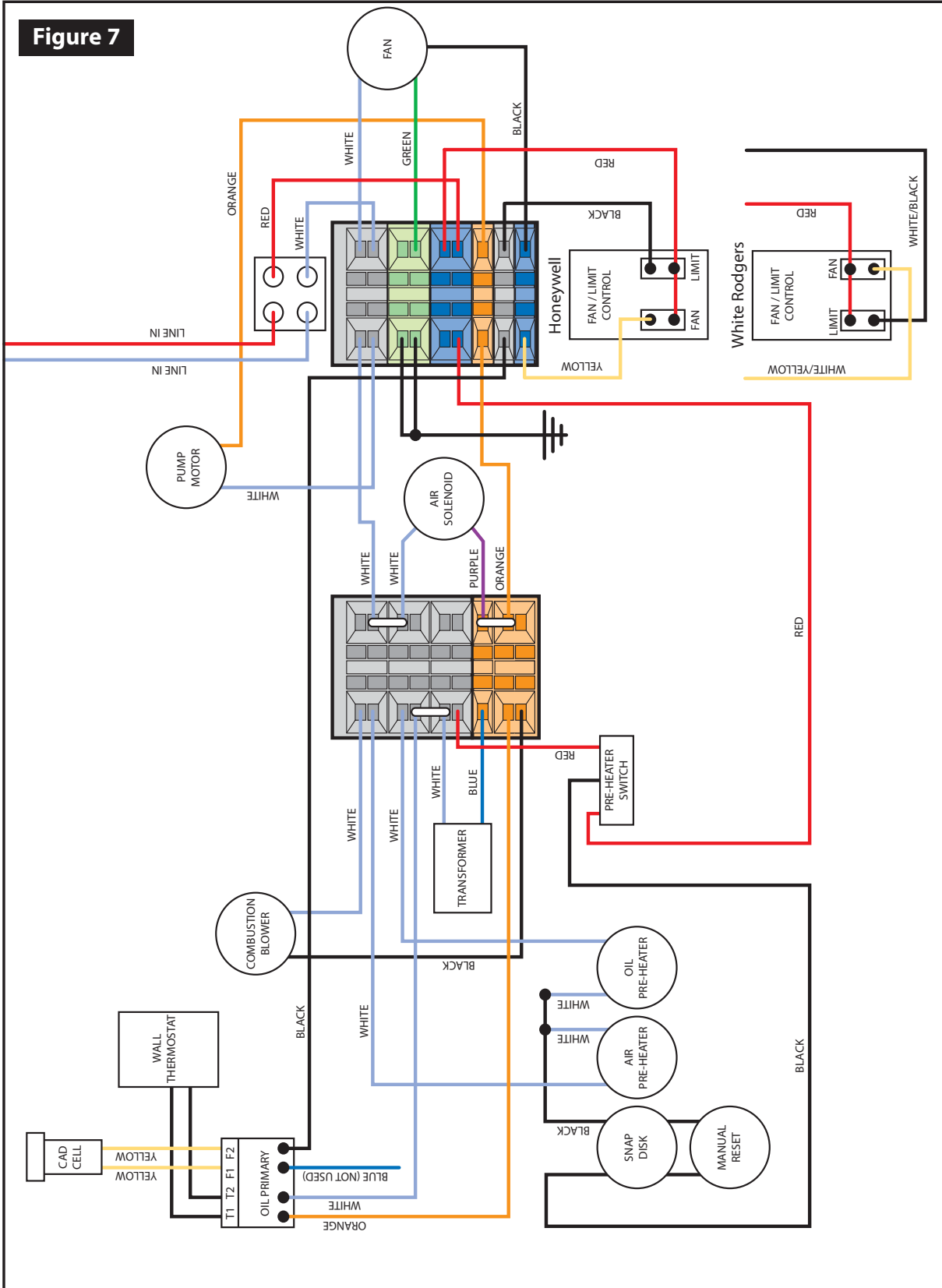

Visit our website at: www.lanair.com



CAUTION: HAZARD OF ELECTRICAL SHOCK!

Fuel Supply Pump Electrical Installation

1. All wiring must comply with the National Electrical Code, State and Local Ordinances, and be wired by a qualified electrician.
2. The electrical conductors to the fuel pump motor **MUST** be stranded 14 GA minimum.
3. The electrical service connections for the fuel pump motor are made in the electrical junction box on the side of the heater.
4. The pump motor **MUST** have a safety equipment ground from the main electrical service, stranded 12 GA minimum.
5. The electrical conductors from the electrical junction box to the pump motor must be within approved conduit.
6. Keep all electrical conductors and conduit away from the chimney connector as well as any other hot surfaces. Refer to Figure 7 Wiring Diagram for color code, etc. Keep the power off until the heater is ready to be started. Refer to Section 11 Start Up Procedure.

Room Thermostat Installation

1. All wiring must comply with the National Electrical Code, State and Local Ordinances, and be wired by a qualified electrician.
2. Install the room thermostat in accordance with the directions furnished with the thermostat.
3. Use two conductor thermostat wire for the connection of the thermostat to the T.T. terminals of the oil primary control that is mounted on top of the burners electrical box.
4. Mount the thermostat 5 feet above the floor on an inside wall away from the heater's warm air path.
5. The electrical current for thermostat is 24 V, and is provided by the oil primary control.
6. Keep the thermostat wire away from the chimney connector, or any other hot surfaces. Refer to Section 2 for a typical thermostat installation.

- **Room Thermostat:**

The room thermostat automatically controls the on/off operation of the heater according to the setting of the desired room temperature. The thermostat works in conjunction with the oil primary safety control.

- **Oil Primary Safety Control/Cad Cell:**

The oil primary control is mounted on top of the burner's electrical box. When the thermostat calls for heat the oil primary control starts the burner by switching on the air solenoid valve, ignition transformer, combustion air blower, and the fuel pump. The oil primary control works in conjunction with the cadmium sulfide cell (cad cell). The cad cell is mounted inside the burner cover, and faces the flame. The cad cell monitors the light level inside the combustion chamber to insure there is a flame present. If there is a loss of flame the primary control will go into its recycle mode. After 1-2 minutes the primary control will restart the burner. When this happens if there is a flame present, the burner will continue to function. If on start up no flame is established in 30 seconds the primary control will lock out.

CAUTION: Do not press the reset button more than twice. If the burner fails to start refer to Section 14 - Trouble Shooting. **Burner has a (2) minute automatic restart feature.**

- **Fan/Limit Control**

The fan/limit control performs 3 functions. The fan/limit control monitors the temperature of the air inside the cabinet. When the air reaches a set point (usually 120° F) it will switch on the heater fan. When the temperature in the cabinet drops below 90° F the fan/limit control will turn the fan off. The Fan/Limit Control contains an external slide switch to turn the axial fan on manual by-passing its automatic function.

The Fan/Limit Control monitors the temperature of the air inside the cabinet. When the temperature exceeds a fixed set point it switches the burner (Oil Primary Control) off until the temperature drops to a safe level. The burner will then restart.

"CAUTION" This means the heater has reached its "High Limit", the cause must be determined and corrected before further use (over firing the unit is normally what causes this condition). The Fan/Limit Control is located on the top on the front of the cabinet.

- **Barometric Draft Control**

The Barometric Draft Control automatically maintains a pre-set chimney draft, and is located in the chimney connector.

- **Air Filter/Regulator**

The Air Filter/Regulator performs two functions: It removes condensation and dirt from the air, and it controls the amount of air pressure reaching the nozzle and air operated fuel valve. The Air/Filter Regulator is mounted on the cabinet near the burner.



- **Electric Air Solenoid Valve**

The Electric Air Solenoid Valve is controlled by the Oil Primary Control. It acts as a shut-off valve, (it's open during operation, and closed when the burner is off). The Electric Air Solenoid Valve is located inside of the burner's electrical box. (See Page 51).

- **Air Operated Fuel Valve**

The Air Operated Fuel Valve controls fuel flow out the nozzle. When the Electric Air Solenoid Valve opens and air pressure pushes on the fuel valve diaphragm, the plunger moves off the nozzle seat allowing fuel to enter the nozzle. The Air Operated Fuel Valve is located on the back of the air pre-heater. (See Page 51).

- **Air/Oil pre-heater**

The Air/Oil pre-heater is an assembly that preheats the atomizing air and fuel to a predetermined temperature to properly combust used oil. The Air/Oil pre-heater is located in the burner (See Page 51).

- **Snap Disc**

The Snap Disc accurately controls the temperature of the air/oil pre-heater assembly with two resistance type cartridge-heating elements. The Snap Disc is mounted on the oil pre-heater inside the burner. (See Page 51).

- **Nozzle**

The Nozzle uses air pressure to help pull fuel through its small orifice, and to atomize the fuel for proper combustion. The Nozzle is located on the end of the air pre-heater opposite the fuel valve. Replace the Nozzle annually, as they are prone to wear by contaminants in waste oil (See Page 47).

- **Fuel By-Pass Regulator**

The Fuel By-Pass regulator controls the pressure of the fuel to the nozzle. The Fuel By-Pass regulator is located in the line between the outlet side of the pump and the burner.

- **Fuel Supply Pump**

The Fuel Supply Pump pumps fuel from your oil storage tank to the burner. The Fuel Supply Pump should be located as close to the fuel supply tank as possible. The Fuel Supply Pump must be mounted horizontally (Shaft).

Section 10 - Priming The Fuel Pump

Priming The Fuel Pump

1. The fuel level in the supply tank must be above the check valve on the pick-up tube.
2. Remove the bowl of the suction line strainer, and fill with clean fuel. Replace the strainer bowl.
3. Remove the two yellow wires from the F-F terminal on the oil primary control. Install a jumper wire between the F-F terminals (see Figs. 8 & 9).

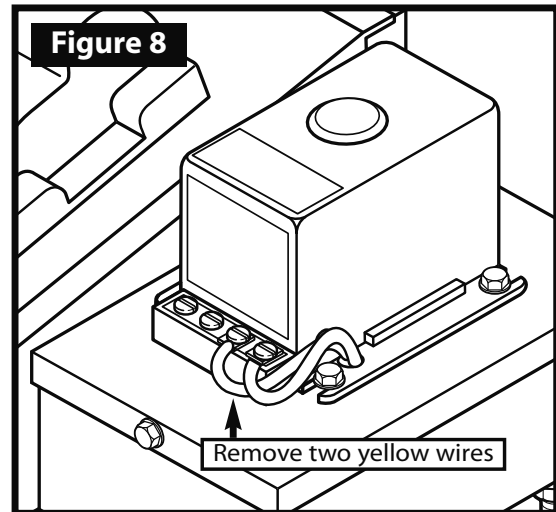

4. Adjust the air filter/regulator on the heater to 18 PSI.
5. Remove the fuel supply line from the burner, and position a container to catch the fuel.
6. Back the thumb screw out (CCW) on the bypass regulator until it is free, then turn (CW) two turns to seat the diaphragm.
7. Loosen the bleeder screw on the pump one turn, and attach a piece of 3/16" ID clear plastic tubing. The tubing should be long enough to allow the fuel to be returned to the tank.

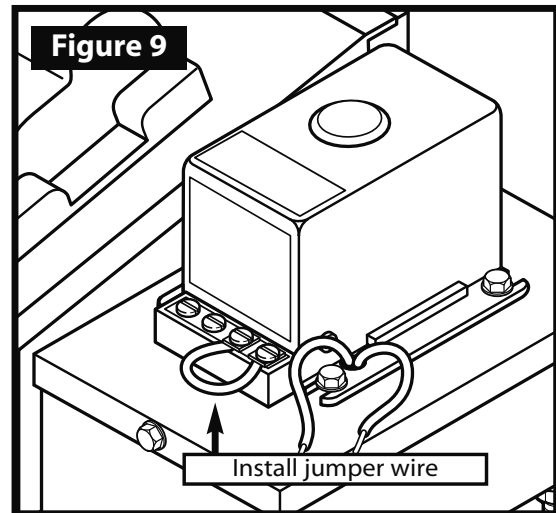

8. Turn the room thermostat above room temperature, or to the "ON" position.
9. Momentarily disconnect one end of the jumper wire at the F-F terminals on the oil primary. The fuel pump will now start.
10. Observe the clear tubing attached to the bleeder screw on the pump. When a steady stream of fuel (no air bubbles) flows close the bleeder screw. Remove the tubing from the bleeder screw.
11. Observe the end of the fuel supply line that is disconnected from the burner. Allow a steady stream (no air bubbles) of fuel to flow into the container for several minutes. This will flush any debris from the fuel line that could potentially plug the nozzle. The vacuum gauge reading should not exceed 5" HG of vacuum.



Section 10 - Priming The Fuel Pump

- 12.** Turn the room thermostat below room temperature or "OFF". The fuel supply pump will now stop.
- 13.** Reconnect the fuel supply line to the burner.
- 14.** Remove the jumper wire from the F-F terminals on the oil primary control, reattach the yellow cad cell wires.
- 15.** Adjust the burner air filter/regulator to 18 PSI.
- 16.** If the fuel supply pump prime, or fuel stream has air in it (spurting, fluctuating flow) there is likely a leak in the suction side of the plumbing. Refer to section 14, trouble-shooting, flow chart #2. The burner should now be ready to fire.

Section 11 - Burner Start-Up Procedure

Waste Oil Burner Start-Up

1. Make sure the main electrical service for the heater is turned off, and locked out.
2. Fill the oil supply tank with an approved fuel to a level that is above the pick-up tube check valve.
3. Check for proper draft in the chimney. The draft must read $-.02$ W.C. cold.
4. Make sure there is air pressure at the heaters air filter/regulator, set at 18 PSI. Set the primary regulator on the air supply line to 30 PSI.
5. Set the fan/limit control slide switch to automatic.
6. Check the combustion air adjustment baffle for proper setting. Refer to Section 15 Flame adjustment.
7. Set the room thermostat below room temperature (OFF).
8. Push the reset button on the oil primary control for 3 seconds.
9. Turn the main electrical service ON.
10. Flip the lighted rocker switch for preheating on the burner electrical box to the ON position (pre-heater OFF the light is off, pre-heater ON the light is on.).
11. Prime the fuel supply pump. Refer to Section 10, Priming the Fuel Supply Pump.
12. If using waste 5W-50W oil, flip the pre-heater rocker switch on (light ON, and wait 5-7 minutes for the pre-heater assembly to reach operating temperature; leave the pre-heater switch OFF if using No. 1 or No. 2 fuel oil).
13. Turn the room thermostat up above the room temperature. The burner will now fire, check the sight glass on the rear of the burner also inspect the flame through the inspection port. (See page 29-31, flame adjustment).
14. Adjust the burner air filter/regulator to 18 PSI, and the primary air regulator to 30 PSI.

NOTE: 18 PSI on the air filter/regulator is the starting point, you may need to adjust from there when **VISUALLY SETTING THE FLAME** (See page 29-31, flame adjustment).



Section 11 - Burner Start-Up Procedure

15. Adjust the fuel pressure gauge on the left side of the burner to read.

	No. 1 & No. 2 Fuel Oil	Approved Waste Oil
Model MX-250	2.25 (2-1/4) - 2.5 (2-1/2) LBS.	2.5 (2-1/2) - 2.75 (2-3/4) LBS.
Model MX-300	3 - 3.25 (3-1/4) LBS.	3.5 (3-1/2) - 3.75 (3-3/4) LBS.

NOTE: Adjust the thumb screw on the fuel bypass regulator clockwise to increase pressure, and counter clockwise to decrease pressure to the burner. The oil pressures listed above are a starting point, you may need to adjust from there when **VISUALLY SETTING THE FLAME** (See page 29-31, flame adjustment).

16. Adjust the barometric damper to obtain a draft of -.06 W.C. while the heater is hot and operating.

NOTE: It is **VERY IMPORTANT** that the barometric damper is set to the required settings to ensure the natural draft of exhaust gases (see section 4).

17. Depending on the type of fuel used, the elevation, temperature, and oil viscosity, the combustion air baffle will need to be adjusted for optimum performance (See page 29-31, flame adjustment).

18. When the room thermostat setting is met the burner will shut off, but the fan will continue to operate until the cabinet temperature drops to 90° F.

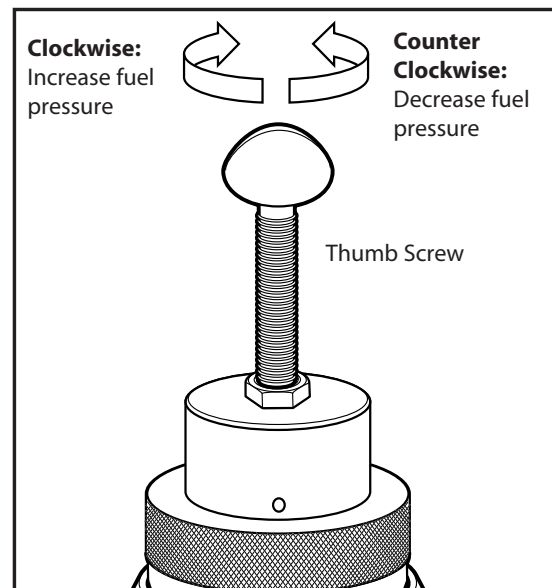

Fuel By-Pass Regulator



The combustion air baffle is NOT factory set

QUESTIONS?... Contact Customer Service at 1-888-370-6531 M-F 8:00 am- 4:15 pm CST

Section 12 - Flame Adjustment

Flame Adjustment

1. Start the heater, let it run for at least 15 minutes to reach operating temperature before proceeding.
2. Check the chimney draft, set the barometric damper to $-.06$ WC when hot and running.
3. Check the atomizing air pressure, set the air filter/regulator on the heater to 18 PSI as a starting point.
4. Check the fuel pressure gauge on the burner, set to:

	Model MX-250	Model MX-300
No. 1 and No. 2 Fuel Oil	2.25 (2-1/4) - 2.5 (2-1/2)LBS.	3 - 3.25 (3-1/4)LBS.
Used Crankcase Oil 10W-50W	2.5 (2-1/2) - 2.75 (2-3/4)LBS.	3.5 (3-1/2) - 3.75 (3-3/4)LBS.

5. Adjust the thumb screw on the fuel by-pass regulator. Lock into position. The flame should extend no more than $3/4$ of the way into the chamber.

NOTE: The above pressure is a starting point, depending on your installation you may need further adjustment. Always **VISUALLY SET THE FLAME**. See page 30.

6. Loosen the combustion air adjustment baffle, slowly close the baffle in $1/16$ " increments until the heater (flame) starts to rumble. Then slowly open the baffle in $1/16$ " increments until the rumbling stops, (wait 2 minutes between adjustments) finally open the baffle an additional $1/8$ " to provide excess oxygen. Secure the baffle, (See Fig. 10).

NOTE: Mechanical equipment like gauges and regulators are not always 100 percent accurate, **VISUAL INSPECTION OF THE FLAME IS REQUIRED** in order to properly dial in the flame settings, see page 30.



The combustion air baffle is NOT factory set

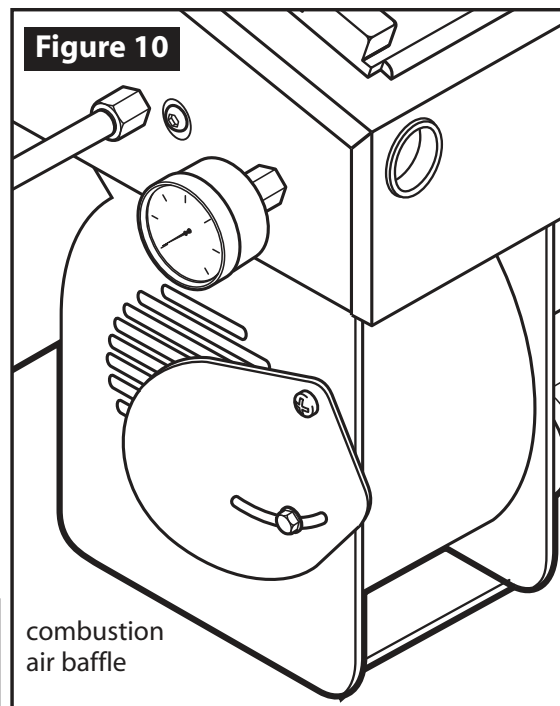



NOTE: ALWAYS WEAR EYE, FACE AND BREATHING PROTECTION AND PROTECTIVE CLOTHING WHEN INSPECTING OR ADJUSTING FLAME.

Lift the inspection port cover on the front of the combustion chamber to observe the flame. The flame tips should extend 3/4 of the way into the combustion chamber. When the unit is adjusted properly the ash inside the chamber will be white to off white.

Flame tips touching the target brick (end of the chamber) will cause combustion chamber damage. This condition may be caused by a worn nozzle, or excess burner fuel pressure. When this condition exists, the ash in the chamber will be brown to black.

Flame Adjustment - Visual

Flame is over-fired (Fig. 11).

- Dark yellow, to orange in color.
- The flame is hitting the walls, filling the chamber with a smokey flame. Correct immediately or chamber may be damaged.
- Decrease fuel pressure, and adjust combustion air baffle. Air pressure may also need to be adjusted.

Problem: Too large of a flame, dark yellow in color.

1. Too much fuel pressure.
2. Not enough combustion air.
3. Not enough atomizing air pressure.
4. Ash inside the chamber is dark brown to sooty black in color.

Flame is under-fired (Fig. 12).

- The flame is like a blow torch.
- Light yellow, to white in color.
- Flame is too short.
- Check to see if pre-heater block is hot.
- Check air PSI, it may be too high. Adjust in 1 LB. increments.
- Oil pressure and the combustion air baffle may need adjustment.



BAD FLAME

The flame is too big, creating an over-fire condition



BAD FLAME

The flame is too short



GOOD FLAME

The flame length is approximately 3/4 of the chamber

Section 12 - Flame Adjustment

Problem: Too small a flame, similar to a blowtorch.

1. Too much atomizing air pressure.
2. Too much combustion air pressure.
3. Not enough fuel pressure.

Solutions:

1. Correct fuel pressure setting.
2. Flame tips reach 3/4 of the way into the chamber.
3. Flame has slightly yellow/orange tips.
4. No black smoke coming from the chimney.
5. Ash inside the chamber is white to off white in color.

Flame is full (Fig. 13).

- Bright yellow in color.
- Flame extends 3/4 into the chamber.
- Flame is not impinging on the chamber walls.

If you need assistance with flame adjustment, please call Lanair's Parts and Service Department.



DO NOT OVER FIRE YOUR HEATER. IMMEDIATELY ADJUST THE BURNER TO THE PROPER FLAME LENGTH TO PREVENT DAMAGE TO YOUR HEATER.



CHECK FLAME DAILY (see page 30). ADJUST ACCORDINGLY

Visit our website at: www.lanair.com



Section 13 - Service / Maintenance

MX SERIES HEATER SERVICE / MAINTENANCE SCHEDULE

DAILY	WEEKLY	MONTHLY	ANNUALLY (Season Shut Down)
<ul style="list-style-type: none"> • Check fuel supply tank level (pre-strain all fuels). • Check vacuum gauge reading on suction line. See Section 19. • Check atomizing air pressure at the air filter/ regulator. Set to 18 psi. Drain water from the bowl if necessary • Check the fuel pressure gauge on the burner. Set to the correct pressure for the fuel being used. • Visually inspect flame. Adjust accordingly. NOTE: Wear adequate eye, face and breathing protection. • Check draft using a manometer. Set draft to -.02 cold, -.06 hot. • If heater is not to be used for more than 48 hours (overnight) flip the pre-heater rocker switch off (light off). 	<ul style="list-style-type: none"> • Drain water/ anti-freeze from the fuel supply tank. • Check the air pressure setting on the primary air regulator. Set to 30 psi. • Drain water from the air pressure supply line drain leg and primary regulator. • Inspect the combustion, ash build-up and flame. NOTE: Wear adequate eye, face and breathing protection. 	<ul style="list-style-type: none"> • Check combustion chamber and heat exchanger. Clean if necessary. Inspect fire brick. NOTE: Wear protective clothing, adequate eye, face and breathing protection. Do not breathe dust from the combustion chamber. Wash thoroughly with soap and water after cleaning chamber. • Clean the chimney, chimney connector and barometric damper. • Clean pump strainer, suction line strainer and pick-up tube strainer (pp 38). NOTE: Always prime pump after cleaning strainers. • Check for dirt build-up on the combustion blower wheel. Keep wheel clean. 	<ul style="list-style-type: none"> • Shut off main power supply to heater. • Perform monthly service/maintenance. • Flip air/fuel pre-heater switch off. • Shut off air supply. • Remove air/fuel pre-heater assembly. Disassemble and clean (pp. 34, 35). • Remove air turbulator and clean (pp. 33) • Replace nozzle and quad ring (pp. 34, 35, 39) • Replace Ignitor (pp 39). • Adjust turbulator (pp 39). • Lubricate all motors following specifications on the motor rating plate. • Clean fuel pump strainer (see pp 38). • Drain and clean fuel supply tank. • Clean combustion blower, axial fan blades and fan cage

QUESTIONS?... Contact Customer Service at 1-888-370-6531 M-F 8:00 am- 4:15 pm CST

Air Pre-Heater Breakdown

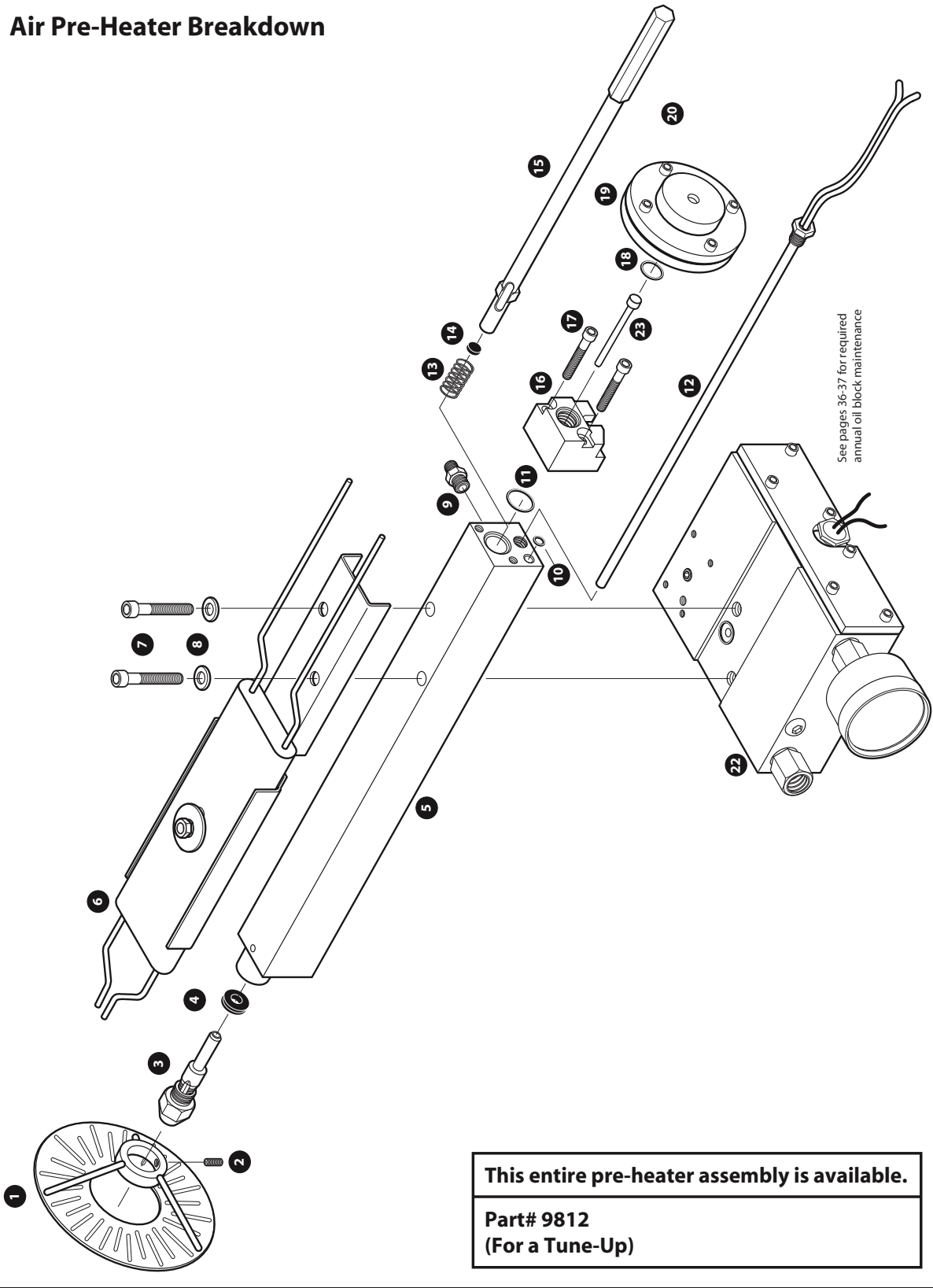

See pages 36-37 for required annual oil block maintenance

This entire pre-heater assembly is available.
Part# 9812
(For a Tune-Up)



Maintenance - Air Pre-Heater

1. Remove Pre-Heater Assembly

- Disconnect the air line from the brass fitting on the air pre-heater and then from the air solenoid and remove.
- Disconnect wiring from the oil pre-heater cartridge, air pre-heater cartridge and snap disc assembly in the wiring junction box.
- Disconnect fuel line and fitting (6) from the oil block (5).
- Disconnect fuel pressure gauge (8) and fitting from the oil block (5).
- Remove button hex screw (14) and washer (11).
- Lift pre-heater assembly and carefully pull straight back. Remove entire assembly from the burner.
- Remove ignitor assembly (6).

2. Remove Diaphragm Assembly from Air Pre-Heater

- Carefully place pre-heater assembly in a vice. **NOTE:** Do not damage pre-heater.
- Unscrew diaphragm assembly (19) from air pre-heater and set aside. Remove o-ring.

3. Remove Adapter Assembly

- Remove hex cap screws (17) and set adapter assembly aside.

4. Remove Plunger, Spring and Cartridge Heater

- Remove spring (13) from plunger (15) and clean both pieces.
- Remove 1/4" o-ring (10) and 11/16" o-ring (11).
- Loosen and remove cartridge heater and set aside.

5. Remove Nozzle Assembly and Quad Ring

- Remove nozzle assembly (3) using a 5/8" wrench.
- If quad ring (4) does not come out with nozzle, carefully remove it.

Ref. No.	Part No.	Qty.	Description
1	9853	1	turbulator
2	-	1	set screw
3	9899	1	nozzle Heater
4	-	1	quad ring
5	9814	1	air pre-heater block
6	3728	1	ignitor assembly
7	-	1	hex cap screw
8	-	1	flat washer
9	-	1	connector
10	-	1	1/4" o-ring
11	-	1	11/16" o-ring
12	9549	1	air cartridge heater
13	-	1	spring
14	-	1	viton insert
15	-	1	plunger
16	-	1	adapter block assembly
17	-	1	hex head cap screw
18	-	1	1/2" o-ring
19	-	1	diaphragm assembly
20	-	1	hex head cap screw
21	-	1	oil pre-heater block

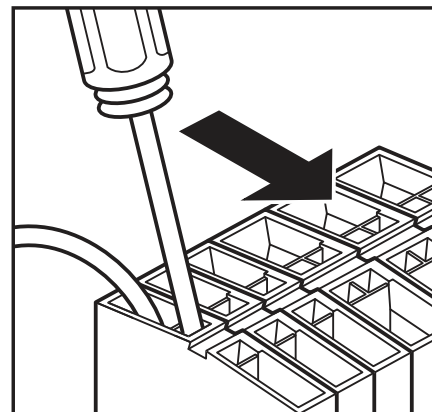

Remove wires from the block by inserting a flat tip screwdriver into the top slot. Push tip all the way down and push forward. Remove wire.

Section 13 - Service / Maintenance

Maintenance - Air Pre-Heater (cont.)

6. Clean all parts using a parts washer

- All passages must be thoroughly cleaned with a brush.

7. Replace Nozzle Assembly and Quad Ring

- After cleaning air pre-heater assembly, blow dry.
- Install new quad ring (4). Before inserting quad ring in air pre-heater block, a light coat of oil should be applied. **NOTE: Make sure quad ring is properly seated in block before proceeding (see page 40 for clarification).**
- Apply a light coat of oil to the shaft of the new nozzle assembly (3). Carefully insert new nozzle assembly (3) through the quad ring and into the block. Hand tighten gently.
- Check alignment of ignitors and adjust if necessary (see page 39).

8. Re-install O-rings and Plunger

- Insert 1/4" o-ring (10) and 11/16" o-ring (11) into the air pre-heater block (5).
- Insert plunger into air pre-heater block spring end first.

9. Re-install Cartridge Heater

- Apply pipe dope to cartridge heater threads. Insert cartridge heater into air pre-heater block and tighten.

10. Re-install Adapter Assembly

- Align the holes of the adapter assembly (16) with those on the air pre-heater block (5). **NOTE: Make sure the small end of the adapter pin is facing toward the air pre-heater block.**
- Attach the Adapter assembly (16) to the block using two hex cap screws (17). Tighten screws.

11. Re-install Diaphragm

- Re-attach diaphragm assembly and hand tighten. **NOTE: Do not over tighten.**

12. Replace Ignitor Assembly (see page 39)

13. Service Oil Pre-Heater (see pages 33-37 for Annual Maintenance Instructions)

THE ENTIRE PRE-HEATER ASSEMBLY IS AVAILABLE
--

PART# 9812

**Oil Pre-Heater
Breakdown**

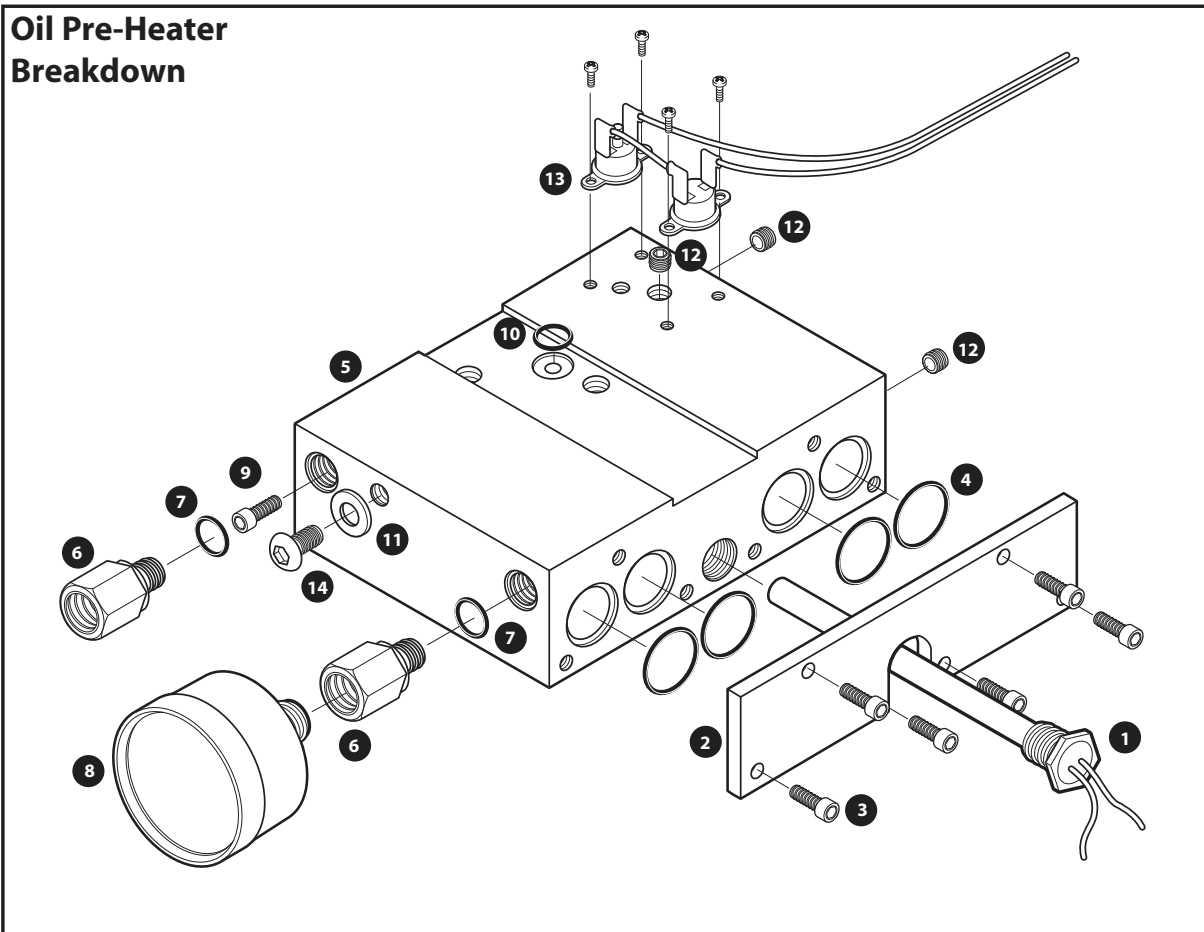

Maintenance - Oil Pre-Heater

1. Separate Air Pre-Heater from Oil Pre-Heater (10)

- Remove o-ring

2. Disassemble Oil Pre-Heater

- Remove six hex cap screws (3) from face plate (2).
- Remove oil cartridge heater (1).
- Remove four 13/16"OD o-rings (4).
- Remove three plugs (12) from oil block (5) **NOTE: Do not discard.**
- Remove hex cap screw (9) from inside oil pre-heater block and clean. **NOTE: Do not discard (9).**

Ref. No.	Part No.	Qty.	Description
1	8992	1	cartridge heater
2	-	1	pre-heater face plate
3	-	6	hex cap screw
4	-	4	o-ring 13/16" OD
5	2902	1	oil block
6	9029	2	fitting
7	-	2	o-ring 5/16" OD
8	8430	1	oil gauge
9	-	1	hex cap screw
10	-	1	o-ring 1/2" OD
11	-	1	washer
12	-	3	plug
13	9533	1	snap disc assembly
14	-	1	button hex screw

QUESTIONS?... Contact Customer Service at 1-888-370-6531 M-F 8:00 am- 4:15 pm CST

Maintenance - Oil Pre-Heater (cont.)

3. Clean Oil Pre-Heater Block

- Clean oil pre-heater block using a parts washer and brush. **NOTE:** Make sure all passages are clean.
- Blow dry the oil pre-heater block. inspect **ALL** passages making sure they are clear and clean.

4. Reassemble Oil Pre-Heater

- Re-install four 13/16" OD o-rings (4).
- Re-install cartridge heater. **NOTE:** Do not over-tighten.
- Re-attach face plate (2) using six hex cap screws (3).
- Apply loc-tite to three block plugs (12) and replace.
- Re-install hex cap screw (9) inside oil pre-heater block (5).
- Re-install o-ring (10).

5. Attach Air Pre-Heater Assembly

- Align the holes of the ignitor assembly and air pre-heater with those of the oil pre-heater (see page 33).
- Attach air pre-heater assembly to the oil pre-heater block (5) using two hex cap screws. Tighten securely.

6. Re-install Pre-Heater Assembly

- Place the air/oil pre-heater assembly into the burner body.
- Align the holes of the pre-heater assembly with those in the burner body.
- Secure the assembly to the body by re-installing the button hex screw (14) and washer (11). **NOTE:** Do not tighten this screw at this time.
- Re-install oil gauge and oil fitting.
NOTE: Do not tighten these fittings at this time.
- Adjust the pre-heater assembly for proper setting. The end of the turbulator should be recessed approximately 1/4" into the burner tube (see page 39 for turbulator adjustment).
- Once adjusted tighten button hex screw (14) and fittings (6) securely.

7. Re-connect Electrical

- Re-connect all wires previously disconnected in the electrical junction box (refer to wiring diagram, page 21 and the burner reference diagram, page 51).

8. Reconnect PSI Gauge, Fuel Line and Air Line

- Reconnect the PSI gauge (8) to the fitting (6) and tighten (**Do Not Over Tighten**)
- Reconnect the fuel line to the fitting (6) and tighten securely.
- Reconnect the air line by connecting the one end of the air line to the air solenoid and the other end to the air fitting (see page 51).

9. Test Operation

- Follow start-up procedure, page 27.

Cleaning Suction Line Strainer

The suction line strainer should be cleaned every 30 days of operation. The element is a washable metal element. If your waste oil is extremely dirty, this strainer may need to be cleaned more frequently. Your vacuum gauge will help you determine when the filter needs cleaning. The vacuum gauge reading should not exceed 5" HG of vacuum. If it does, the strainer needs cleaning.

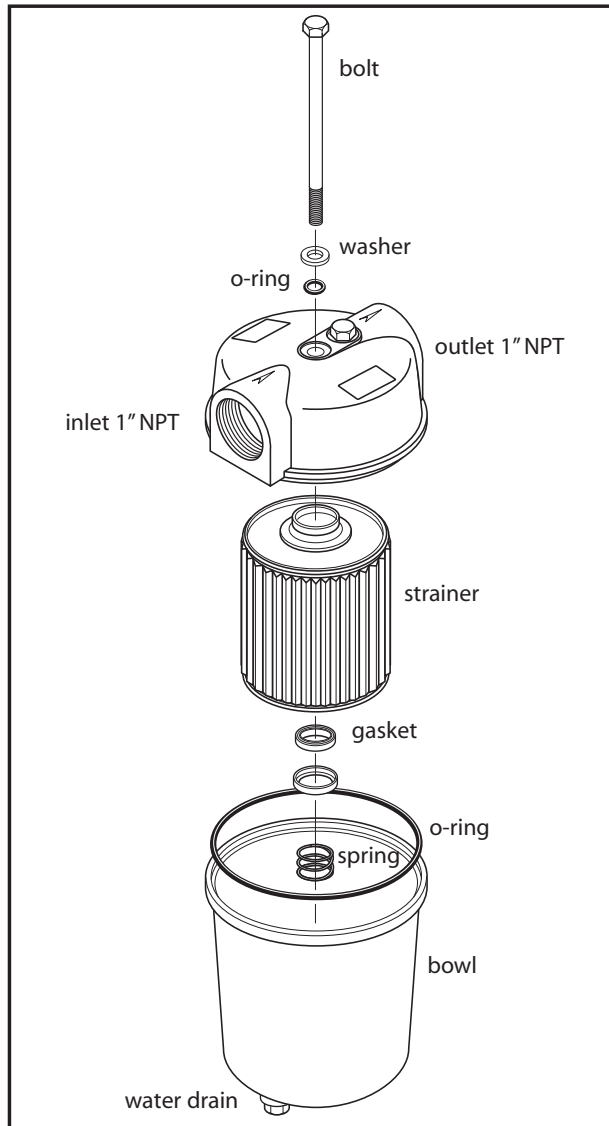

1. Disconnect power to the heater.
2. While holding the lower housing, unscrew the center bolt on the top of the suction line strainer.
3. Rinse the filter and lower housing in solvent.
4. Air dry the strainer and lower housing.
5. Re-assemble the strainer, ensuring the rubber gaskets, spring and o-rings are in place.
6. Fill the lower housing with waste oil or fuel oil.
7. Position the lower housing to the top making sure the o-ring is properly seated. Secure the top and bottom together using the bolt, washer and gasket removed earlier.
8. Prime the fuel pump (see page 25).

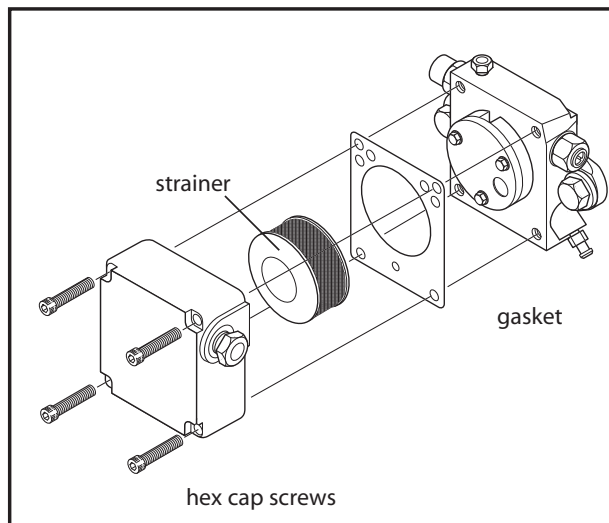

Cleaning/Replacing Fuel Pump Strainer

1. Disconnect power to the heater.
2. Remove four hex head screws from pump cover. Carefully remove cover, strainer and gasket.
3. Clean housing, strainer and pump surface. Check for excess wear.
4. Install a new gasket (P/N 9817).
5. Install strainer and pump housing.
6. Prime the fuel pump (see page 25).

Ignitor Replacement / Adjustment

1. Disconnect power to the heater.
2. Remove the pre-heater assembly from the burner housing. Disassemble and clean all parts as instructed on pages 33-37.
3. Using a 1/4" Allen wrench, carefully remove the one-piece ignitor from the air pre-heater.
4. Install a new one piece ignitor (P/N 3728) to the top of the air pre-heater. **NOTE:** The tips of the ignitor should be 3/8" above the center of the nozzle assembly and should extend approximately 1/8" beyond the end of the nozzle. The tips of the one piece ignitor should be 1/8" apart. Adjust as required and tighten nut on the top of the ignitor (see illustrations for clarification of placement).
5. Re-assemble pre-heater assembly (see pages 33-37) carefully re-install the pre-heater assembly into burner housing. The turbulator should be approximately 1/4" from the end of the burner tube. Adjust as required and secure the pre-heater assembly to the burner housing by tightening the adjustment screw on the side of the burner housing (see illustration).

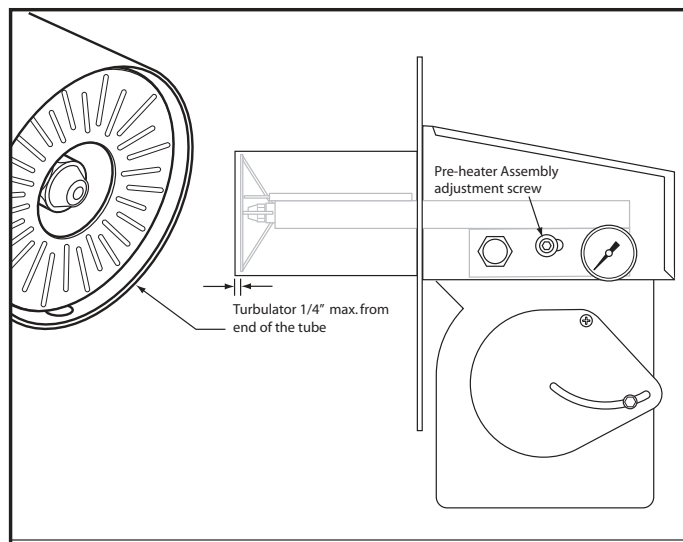
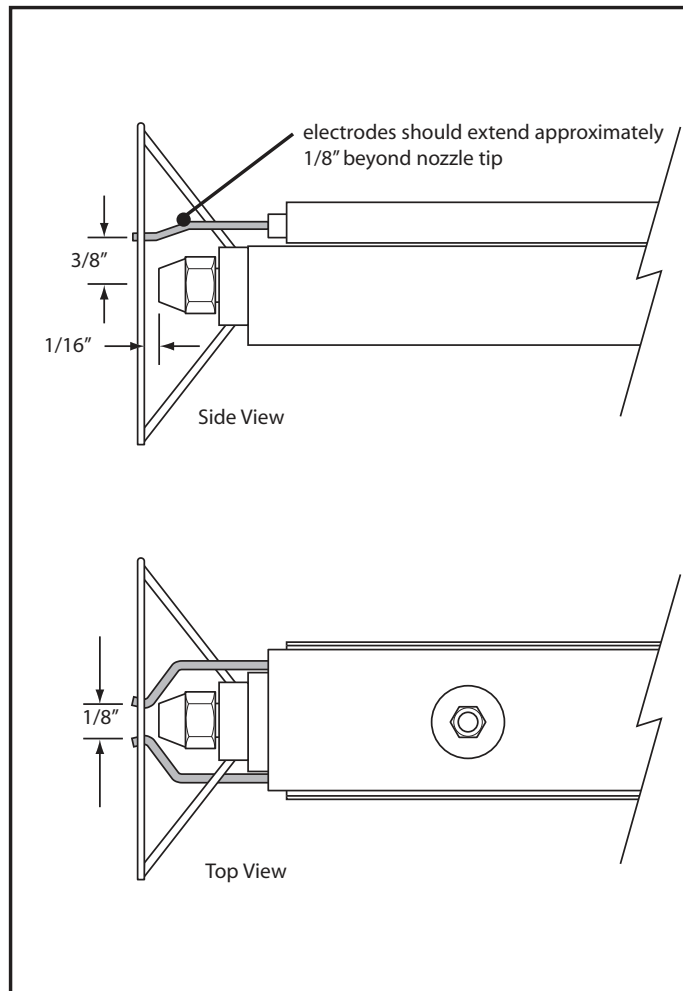

Air Pre-Heater Diaphragm Breakdown

1. Remove the four hex cap screws from the diaphragm assembly
2. Disassemble and inspect diaphragm, spring and o-ring .
3. Thoroughly clean remaining parts.
4. Re-assemble the diaphragm, o-ring, spring and hex cap screws.

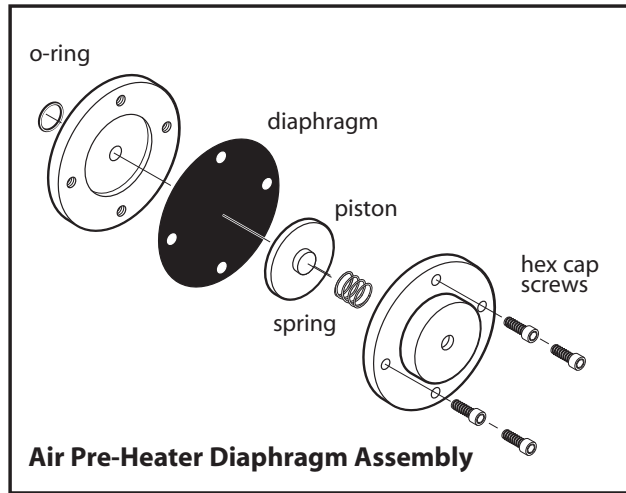

Air Pre-Heater Nozzle Cleaning / Replacement

1. Periodic cleaning of the nozzle assembly may be required.
2. Carefully remove nozzle from the air pre-heater block.
3. Disassemble the nozzle as shown and clean thoroughly. Re-assemble nozzle.
4. Carefully remove the quad ring from the block and inspect. Replace if necessary.
5. Insert clean/new quad ring into the air pre-heater block. **NOTE:** The quad ring must be properly seated. Failure to properly seat the quad ring may result in leakage and improper burner operation. **DO NOT INSTALL QUAD RING ON THE NOZZLE.**
6. Lubricate pin/seat and re-install nozzle. Tighten gently.

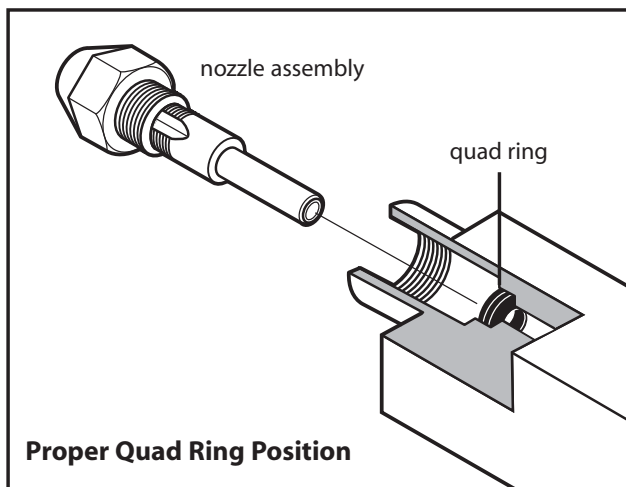
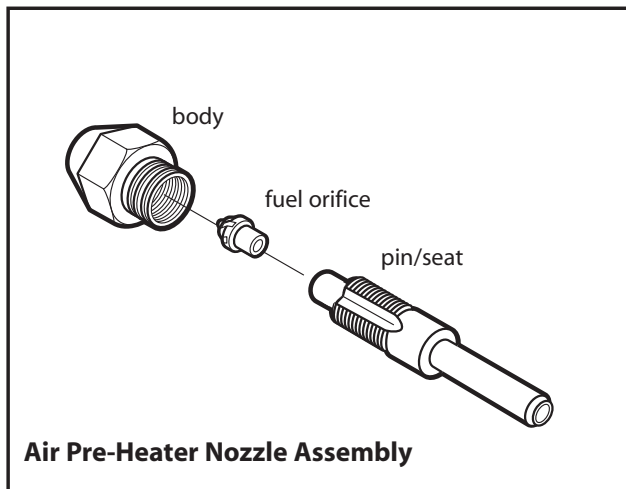

! Failure to properly seat the quad ring may result in leakage and improper burner operation. DO NOT INSTALL QUAD RING ON THE NOZZLE.

Section 13 - Service / Maintenance



NOTE: ALWAYS WEAR EYE, FACE AND BREATHING PROTECTION AND PROTECTIVE CLOTHING WHEN INSPECTING OR CLEANING CHAMBER OR HEAT EXCHANGER.



WARNING: DISCONNECT ALL ELECTRICAL POWER TO HEATER BEFORE SERVICING

Cleaning Combustion Chamber/ Heat Exchanger

1. Turn thermostat to the lowest setting; the heater must be completely cool to the touch before attempting to clean the heater (place the fan/limit on the manual position to start the fan and shorten the cooling time if the unit is hot).
2. Turn off all power to the heater (120 VAC) at the main disconnect. Place the fan/limit switch lever back into the auto position so the fan is off upon restarting.
3. Remove the burner and flame view port from the heater. Remove the galvanized panel covering the clean-out cover (remove four (4) #10 screws from the top and four (4) #10 screws from the bottom of the panel and remove).

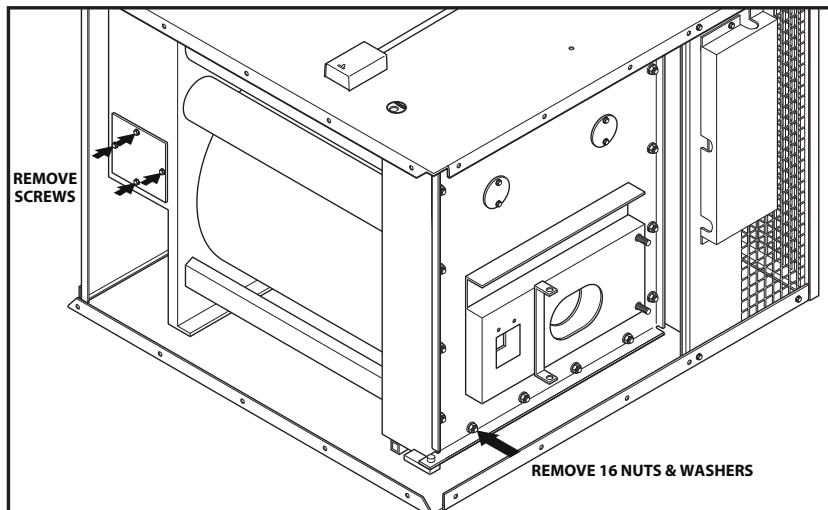
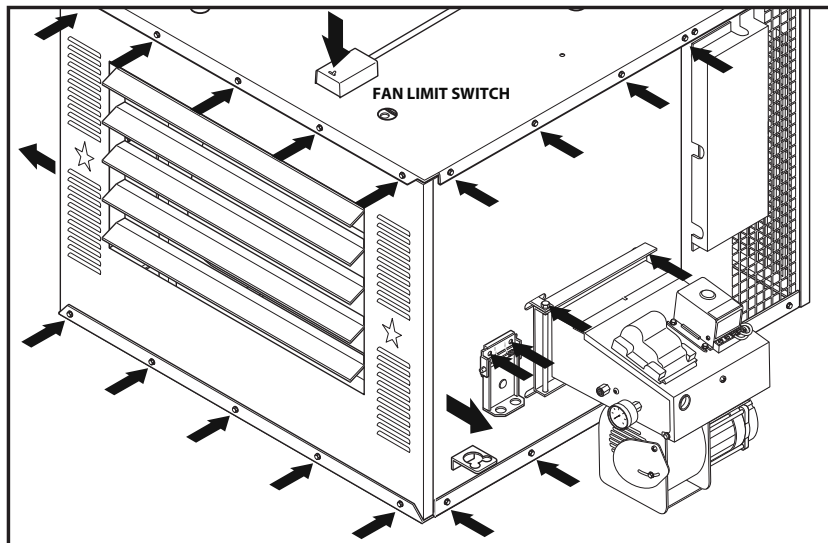

4. **Spray all of the screws with penetrating oil to prevent breakage before removing any of the nuts that secure the combustion chamber access door. Let set for five minutes to allow the oil to penetrate.**
5. Remove the clean out cover from the heater by removing (16) 1/2 hex head nuts & washers. If more than 1/4" of ash is present clean the heat exchanger tubes.

Visit our website at: www.lanair.com



Section 13 - Service / Maintenance



CAUTION: THE CLEAN OUT PANEL MUST HAVE AN AIR TIGHT SEAL TO PREVENT EXTREME DAMAGE TO THE COMBUSTION CHAMBER



CAUTION: TO AVOID BOLT BREAKAGE, DO NOT OVER-TIGHTEN

6. Use an industrial type canister vacuum cleaner with a high efficiency filter, or suitable tool. Failure to clean heat exchanger tubes annually will impair draft. Reaching through the burner opening, vacuum or shovel the ash from the combustion chamber. Inspect the combustion chamber and target brick. Use care when cleaning the combustion chamber area so the target brick is not disturbed. Insufficient or irregular cleaning intervals will cause inefficiency, random shutdowns, and extreme damage to the combustion chamber.
7. Before replacing the combustion chamber access doors, replace the white gasket seal on the door (contact the Lanair Service Department). When replacing the gaskets apply a light film of gasket adhesive to adhere the new gasket to the door. Lube the threads of the screws with a high temperature lubricant. Re-install the heat exchanger access panel. If any nuts are stripped, replace (use brass).
8. Replace the inspection port with the two (2) #8 hex head sheet metal screws (if removed). Re-install the clean out cover. Replace burner.
9. Remove the front panel of the unit by removing (10) #10" sheet metal screws. Slide the front panel of the unit to the right side of the heater far enough to expose the manifold clean out port.
10. On the left side facing the front of the unit remove the (4) #10 sheet metal screws from the manifold clean out ports. Using an industrial type canister vacuum cleaner with a high efficiency filter, remove all ash accumulation.
11. The chimney connector can also be removed to allow access to the manifold for cleaning. Clean and inspect the chimney connector if necessary. Replace the four (4) #10 screws in the clean out ports on the heater. Replace the front of the cabinet replacing the ten (10) #10 sheet metal screws. Check your draft reading to make sure your barometric damper is properly set (See Section 4).
12. Reconnect all power at the main breaker box, wait ten minutes before turning the thermostat up. Your heater is now ready for normal operation.

NOTE: When changing the target brick, call the Lanair Service Department for assistance.



WARNING: DO NOT OPERATE YOUR FURNACE WITH CLEAN OUT PANELS OR PORTS REMOVED

QUESTIONS?... Contact Customer Service at 1-888-370-6531 M-F 8:00 am- 4:15 pm CST

Fuel By-Pass Regulator Assembly

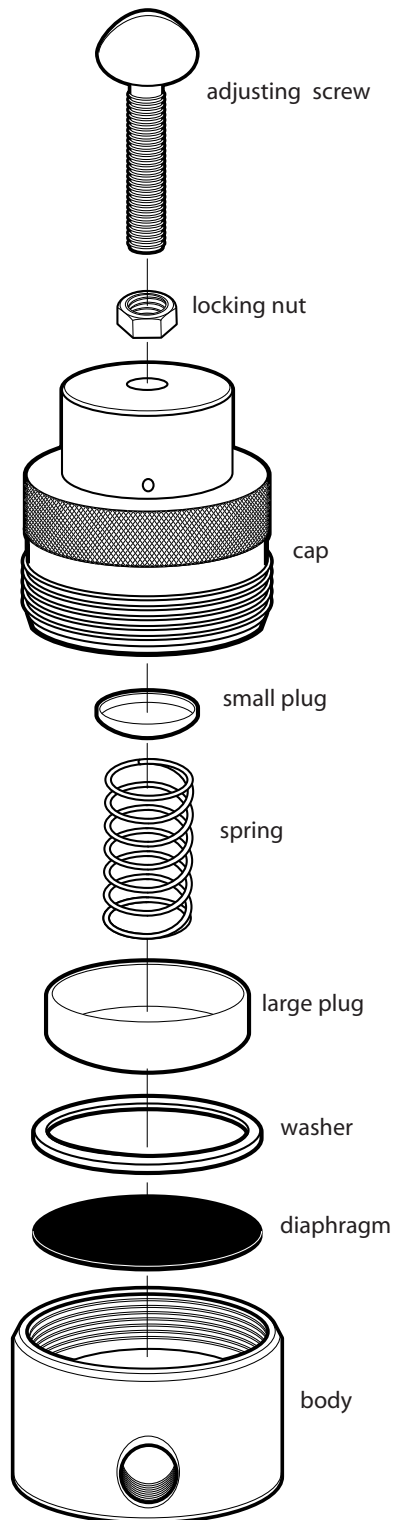

Fuel By-Pass Regulator Diaphragm Replacement

1. Disconnect power to the heater.
2. Remove the locking nut and adjusting screw from the by-pass regulator assembly.
3. Disassemble the by-pass regulator and discard the small plug, spring, large plug, washer and diaphragm.
4. Thoroughly clean and dry remaining parts.
5. Re-assemble using new small plug, spring, large plug, washer and diaphragm (Kit P/N 9874).

NOTE: Pay close attention to the positions of the large and small plugs.



Initial Diagnosis:

When an operating problem occurs, a determination must be made whether or not the fuel pump is pumping a sufficient amount of oil that contains no air or water.

Take these steps:

- Adjust the burner air regulator to -0- PSI.
- Turn pre-heater rocker switch off (red light off).
- Shut off oil supply line valve to the burner.
- Remove the fuel supply line from the supply tank.
- Attach a flexible piece of tubing at least 3 feet long to the outlet on the return side of the oil by-pass regulator.
- Insert the tubing into the bottom of a large jar.
- Jump the cad cell circuit and start the fuel pump (see below).
- Attempt to fill the jar above the open end of the tubing.
- If the pump will not pump fuel, attempt to prime the pump (Section 10). If the pump won't prime refer to Flow Chart Item B.

If no air or water is present the flow must be determined.

- Pump fuel for 1 minute into a graduated container, if the flow rate is less than 250 MILS/Minute (8-1/2 Ounces), refer to Section 14 Troubleshooting Chart Item B.

If the flow rate is more than 250 MILS/minute (8-1/2 Ounces), refer to Troubleshooting Chart Item C.

After repairs are made, remove the cad cell jumper wire, and reconnect the cad cell wires to the oil primary.

By-passing the oil primary safety circuit:

Some trouble-shooting test may require the cad cell safety circuit in the oil primary control to be bypassed, to do this:

- Remove the 2 yellow wires from the F-F terminals on the oil primary control.

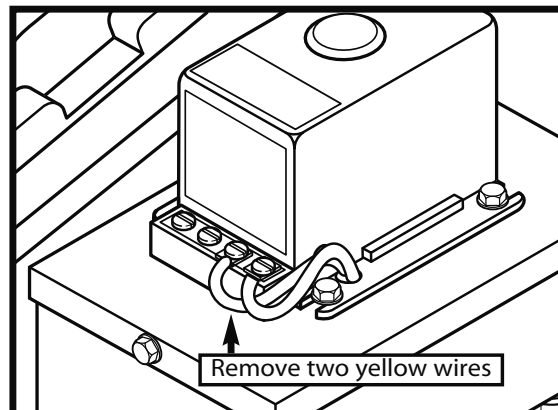

WARNING: DO NOT OPERATE YOUR HEATER IF THE OIL PRIMARY SAFETY CIRCUIT IS NOT WORKING!

QUESTIONS?... Contact Customer Service at 1-888-370-6531 M-F 8:00 am- 4:15 pm CST

Section 14 - Troubleshooting

- Install a jumper wire between the two F-F terminals.
- Push reset button for 2 seconds.
- Turn room thermostat up so that it calls for heat.
- Disable the air operated fuel valve.
- To activate the oil primary momentarily disconnect one end of the jumper wire on the F-F terminals. The burner will attempt to fire.

IMPORTANT remove the jumper wire when testing is complete, and replace the cad cell wires. **Do not run the heater with the cad cell wires disconnected.**

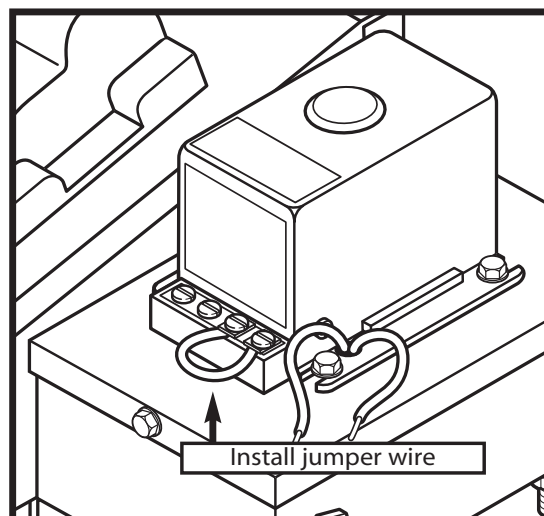

Disabling the air operated fuel valve.

Note: Most trouble shooting tests will require the air operated fuel valve to be disabled, to do this:

- Adjust the heater air filter/regulator to -0- PSI.

Vacuum Gauge reading hints:

No reading 0-1 HG

- Pump not operating.
- Pump air locked and needs priming. Refer to section 10.
- Vacuum leak: ✓ Pump shaft seal
 ✓ Suction strainer gaskets
 ✓ Pipe connections suction side
- ✓ Pump cover gasket
 ✓ Low fuel level in tank
 ✓ Strainer in pump cover

Low to normal reading, 1-6 inches HG.

- Pump operating properly.
- Fuel oil is being used.
- High level of gasoline in the fuel (use approved fuels only).
- Fuel being used has a low viscosity.
- Fuel is at room temperature (warm).

High reading, 7 inches of HG, or more.

- Fuel being used has too high of a viscosity.
- Fuel is too cold.
- Fuel contains gear lubes (use approved fuels only).
- Suction line strainer dirty or plugged.
- Check valve installed wrong or stuck.

Reading fluctuates (jumps).

- Vacuum leaks in the suction side of the piping to the pump.
- Low fuel level in the tank.



Burner fuel pressure gauge reading hints:

Fuel gauge fluctuates (jumps):

- Leak in suction line plumbing.
- Water/anti freeze in fuel.
- Air in fuel, refer to Troubleshooting Chart Item B.
- Quad ring seal for the nozzle may be damaged.
- Seal in adapter block may be worn or damaged.
- Fuel pressure regulator seal leaking or dirty.
- Suction line strainer plugged or dirty.

Reading gradually decreases:

- Fuel pump output decreasing.
- Fuel viscosity decreasing.
- Orifice in nozzle is wearing.

Reading gradually increases:

- Fuel pump output increasing.
- Fuel viscosity increasing (cold fuel, and/or gear lube).
- Orifice in nozzle is becoming plugged.

Reading drops to -0- PSI when the burner is off.

- Dirt between the diaphragm and the seat in the by-pass regulator.
- Dirt between the plunger and the nozzle seat.
- Leak in the plumbing connections.
- Leak in the pre-heater assembly (damaged or missing o ring).
- Fuel pre-heater switch is off.

Steps to check the air operated fuel valve:

- Disconnect the two transformer wires from the terminal block in the burner.
- Jump the cad cell circuit (refer to pages 44-45).
- Disconnect the fuel supply pump orange wire from the terminal block inside the burner.
- Set the dial indicator as shown on the diaphragm piston.
- Zero the dial indicator.
- Start the burner so that the air valve opens.

NOTE: The dial indicator should read +.015 to .050, which references the diaphragm piston travel.

Section 14 - Troubleshooting

Symptom	Possible Cause	Corrective Action
A. Burner will not start	1. Main electrical power circuit breaker tripped	1. Reset breaker
	2. Service disconnect switch off or fuse blown	2. Turn switch on or replace fuse
	3. Thermostat turned down/ improperly installed/ defective	3. Turn thermostat up, check wires/test components/replace
	4. Oil primary safety tripped/defective	4. Reset/test components, replace if needed
	5. Too much light showing on cad cell/defective	5. Eliminate light to cad cell Test component
B. Burner attempts to fire, but does not establish a flame	1. Low oil in supply tank or contaminated fuel	1. Fill tank, or drain and clean tank
	2. Plugged or worn nozzle	2. Clean or replace
	3. Fuel pressure gauge fluctuating/pumping system	3. See section 6, Page 17
	4. Pre-heater switch is turned off or defective, or defective cartridge heater	4. Turn switch on or test switch and cartridge heater
	5. Transformer/electrodes not sparking	5. Test transformer/look for shorts & repair Replace electrodes/ transformer
	6. No air pressure/defective regulator/defective solenoid	6. Turn compressor on/test regulator/solenoid. Replace defective components
	7. Water in air system	7. Clean air pre-heater and drain water from system
	8. Combustion blower not properly adjusted or defective	8. See flame adjustment pages 29-31. Replace blower
	9. Improper draft	9. Check draft see page 15. Make sure chimney is properly installed
	10. Plugged heat exchanger, or chimney	10. Clean heater including manifold, chimney

Visit our website at: www.lanair.com



Section 14 - Troubleshooting

Symptom	Possible Cause	Corrective Action
C. Burner fires, and then fails on oil primary safety	1. Contaminated fuel supply (water/anti freeze/gear lube) or dirty fuel filter.	1. Drain and clean fuel supply tank. Clean fuel filter (see page 38)
	2. Improper draft	2. Check draft see page 15. Make sure chimney is properly installed
	3. Plugged heat exchanger, manifold, or chimney	3. Clean heater including manifold and chimney
	4. Wrong air pressure	4. See flame adjustment pages 29-31
	5. Wrong fuel pressure or pressure fluctuating	5. See flame adjustment pages 29-31. See fuel piping page 17
	6. Improper combustion blower setting, or blower is defective	6. See flame adjustment pages 29-31. See fuel piping page 17
	7. Oil primary/cad cell defective. Cad cell improperly adjusted. Dirty flame turbulator.	7. Test components/adjust cad cell/ clean turbulator
	8. Plugged nozzle or pre-heater assembly	8. Clean nozzle and /or pre-heater assembly
D. Pre-heater assembly not heating	1. Cartridge heaters defective or disconnected	1. Test cartridge heaters using an ohm meter. Air heater 112 Ω ±10%. Oil heater 37 Ω ±10%.
	Snap disc defective	2. Test snap switch for continuity if pre-heater is cold

QUESTIONS?... Contact Customer Service at 1-888-370-6531 M-F 8:00 am- 4:15 pm CST



Return Guidelines

1. All returned merchandise must be unused and returned in the same new condition in which it was originally received, with all accompanying original packaging. Any items returned used, damaged in any way or with missing components will not be refunded. Return merchandise must be shipped freight prepaid.
2. All returns must be authorized by the Lanair Customer Service Department. Unauthorized returns will NOT be accepted or refunded, and may be refused when received.
3. Authorized returns for merchandise in original boxes and in new condition are subject to a 20% restocking charge. No returns are accepted on custom or special order items. Electrical components maybe subject to inspection.
4. All returns must be made within fifteen (15) days after the date of the shipment for orders within the United States. For foreign orders, the return must be made within sixty (60) days of the initial shipment.
5. All authorized returns will be fully refunded less restocking fees, shipping and handling charges.
6. To obtain an authorization number, please call our customer service department at **1-888-370-6531**, or email us at **service@lanair.com**
7. All authorized returns must have the authorization number marked on the outside of the package and returned to the following address:

**Lanair Products LLC
Returns Department
4109 Capital Circle Drive
Janesville, WI 53546**

Warranty Conditions

Lanair Products LLC (Manufacturer) warrants to the original purchaser of this used oil heater, that it will repair or replace at Lanair Products LLC's option, any part which is in normal use proves to be defective in material or workmanship within a period of one year from the date of purchase, provided same is returned (transportation pre-paid) F.O.B. Janesville Wisconsin, for Lanair Products LLC's inspection and warranty determination. Normal wear and tear items are not covered. Lanair Products does not warrant paint finish. The warranty does not cover labor charges involved with part replacement or service unless pre-authorized in writing. Lanair Products LLC may also require photographs of the heater installation for warranty determination.



LANAIR 10 YEAR WASTE OIL HEATER COMBUSTION CHAMBER AND HEAT EXCHANGER LIMITED WARRANTY

Lanair Products LLC, MANUFACTURER, hereby warrants that any part of manufacturer's product shall be free from defect in material and workmanship under normal use according to the provisions and limitations herein set forth for a period of one (1) year provided same is returned (pre-paid) F.O.B. Janesville, Wisc. for inspection and warranty determination.

MANUFACTURER warrants the heat exchanger/combustion chamber for three (3) years from the date of purchase and pro rata thereafter according to the following schedule: If a defect occurs during the first three years, MANUFACTURER will repair or replace the combustion chamber/heat exchanger FREE of charge. If a defect occurs in years four through ten (4-10) MANUFACTURER will repair or replace your combustion chamber/heat exchanger. Your guaranteed replacement cost will be shared by MANUFACTURER 50/50.*

***IMPORTANT:** Combustion chamber / heat exchanger must be maintained in accordance with the installation / operating instructions. This extended warranty does not cover normal wear items such as gasket material, chamber inserts, nuts, bolts, labor costs, etc. The warranty card must be returned within ten (10) days of purchase date in order for this warranty to be valid. Warranty is limited to original purchaser.*

**MANUFACTURER'S determination regarding repair or replacement is final.
Cost of freight is owner's responsibility.*

Model Number: MX Series Heater

Date Purchased: _____

Conditions That Will Void Warranty

- Use of liquids such as: solvents, brake fluid, gasoline, K-1, kerosene, paint thinners, gear lube, transformer oil, cutting oils, anti-freeze, water or any other liquid not approved for use.
- Tampering with internal components
- Failure to inspect and clean combustion chamber/heat exchanger at the end of each heating season.
- Continuous over-firing of the unit
- Heater has not been installed or serviced in accordance to the installation / operating manual.
- Alteration or misuse of any part
- Use of parts other than those supplied by Lanair.

NOTE: Lanair may require photographs of the heater installation for warranty determination

NOTE: Re-stocking fee of 20% applies on all returned parts

Items Not Covered Under Warranty

- Any portion of the combustion chamber / heat exchanger if:
 - The unit is not installed per the owners manual.
 - The yearly inspection requirements are not current.
 - If the heater is used for a purpose for which it is not intended.
 - If the heater is not operated in accordance with the printed instructions in the
 - If any alterations or unauthorized repairs are made to the unit.
- Damage incurred from abuse, neglect, shipping, natural acts, misuse or accident.
- Labor costs for service calls for any reason including:
 - Cleaning or performing required maintenance.
 - Installation corrections
 - Any parts installation.
- Parts that are replaced because of normal wear and tear.
- Goods purchased under this agreement shall be used exclusively by the buyer and no other person or third party shall benefit from the express or implied warranties contained in the agreement.

QUESTIONS?... Contact Customer Service at 1-888-370-6531 M-F 8:00 am- 4:15 pm CST

Section 16 - Burner Reference Diagram

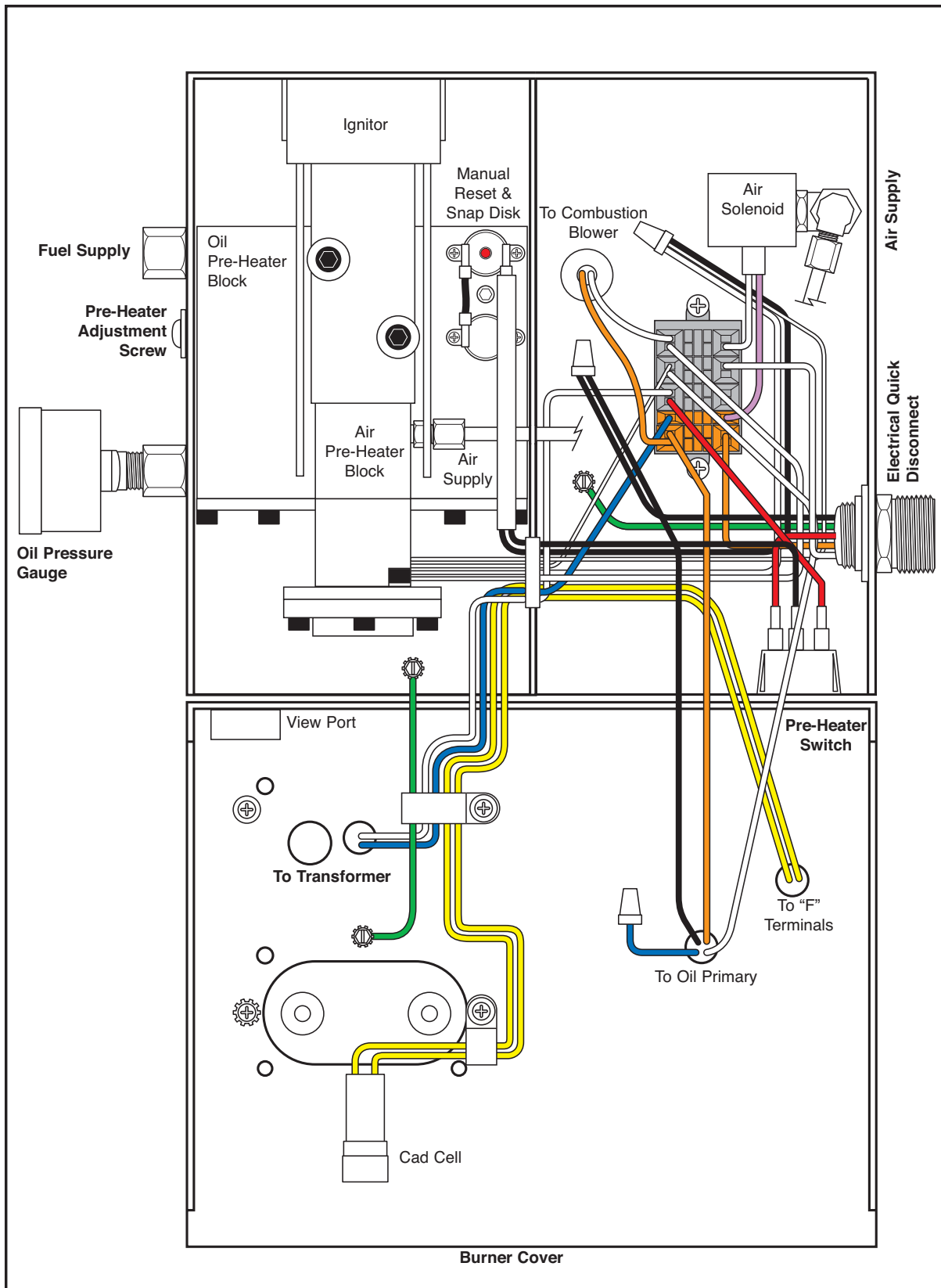

Visit our website at: www.lanair.com



Lanair Products LLC
4109 Capital Circle
Janesville, Wisconsin 53546
1-888-370-6531
www.lanair.com